

MARINE TRANSMISSION CAPACITY TABLES



Table of Contents

Service Classification	1
Definitions	
Important Application Information	2
Pleasure Craft	5–14
Standard and QuickShift® Marine Transmission Ratings	
Light Duty	15–22
Standard and QuickShift® Marine Transmission Ratings	
Intermediate Duty	23–34
Standard and QuickShift® Marine Transmission Ratings	
Medium Duty	35–44
Standard and QuickShift® Marine Transmission Ratings	
Continuous Duty	45–56
Standard and QuickShift® Marine Transmission Ratings	
MG-300, MG-500, MG-5000 and MGX-5000	57–62
Standard and QuickShift® Marine Transmission Dimensions	
MG-6000 and MGX-6000	63–65
Standard and QuickShift® Marine Transmission Dimensions	

SERVICE CLASSIFICATION DEFINITIONS

Pleasure Craft

Up to 500 hours/year, low load factor usage planing hull vessels where typical full engine throttle operation is less than 10% of total time. The balance of operation at 80% of full engine throttle or less. Marine transmissions for use in long range pleasure cruisers, sportfish charter boats/patrol boats do not qualify for Pleasure Craft Service.

Note: Some revenue producing applications such as Planing Hull Bristol Bay Gillnetter do qualify under Pleasure Craft rating definition.

Light Duty

Relatively low hour usage (less than 1500 hours/year) where full throttle operation is 2 hours out of 12. Typical applications include planing hull vessels such as fire boats, sportfish charter boats, and patrol/customs boats. This rating is also applicable to some bow and stern thruster applications.

Intermediate Duty

Hour usage of up to 2000 hours/year (for models MG-5114 and smaller) and up to 3000 hours/year (for models larger than MG-5114) with 50% of the operating time at full engine rating.

Typical applications include planing hull vessels such as ferries, fishing boats, some crew boats, and also some displacement hull yachts as well as some bow and stern thruster applications.

Medium Duty

Hour usage of up to 4000 hours/year with up to 80% of operating time at full engine power. This duty classification is for usage where some variations in engine speed/power occur as part of normal vessel operation.

Typical vessels include mid-water trawlers, crew/supply boats, ferries, and some inland water tow boats.

Continuous Duty

For use in continuous operation with little or no variation in engine speed/power settings.

Typical vessels include fishing trawlers, tow/tug boats and ocean going vessels.

IMPORTANT APPLICATION INFORMATION

- Transmission ratings are based on use of the transmission in a torsionally compatible system utilizing a suitable input torsional coupling.
- Ratings are for diesel engines at the indicated speeds, unless otherwise indicated.
- Ratings are shown in SAE horsepower (HP).
- Consult factory for ratings applicable to gasoline engines, gas turbines, or other applications not conforming to the given service class definitions.
- Ratings apply to right hand engines (i.e., counter-clockwise flywheel rotation when viewing rear of engine).
- Ratings are full power forward or reverse except where specified by "F" (using forward gear train for forward).
- Transmission ratings should equal or exceed the engine's published ratings for the given application.
- Final marine transmission selections are to be confirmed prior to issuance of the purchase order. For unusual or unique applications, please contact Twin Disc, Inc. for product selection assistance.
- Marine transmission input couplings provided by Twin Disc are configured to interface with engine flywheels which conform to SAE J620 standards. Please consult Twin Disc when use of non-standard flywheels are contemplated.
- Most of the transmissions listed herein are to be mounted directly on the SAE flywheel housing of the engine. It is necessary that the engine crankshaft end-play be measured before the driven equipment is installed and rechecked after the driven equipment is installed. The endplay measurements, before and after transmission installation, should be the same. If not the same, the driven equipment should be removed and the problem source located and corrected before the engine is started. Engine crankshaft endplay measurement is considered mandatory.
- The given data is subject to modifications/corrections without prior notice.
- Use certified print for installation.

IMPORTANT NOTICE

Disregarding propulsion system torsional compatibility could cause damage to components in the drive train resulting in loss of mobility. At minimum, system incompatibility could result in gear clatter at low speeds.

The responsibility for ensuring that the torsional compatibility of the propulsion system is satisfactory rests with the assembler of the drive and driven equipment.

Torsional vibration analysis can be made by the engine builder, marine survey societies, independent consultants, and others. Twin Disc is prepared to assist in finding solutions to potential torsional problems that relate to the equipment of Twin Disc Incorporated's supply.

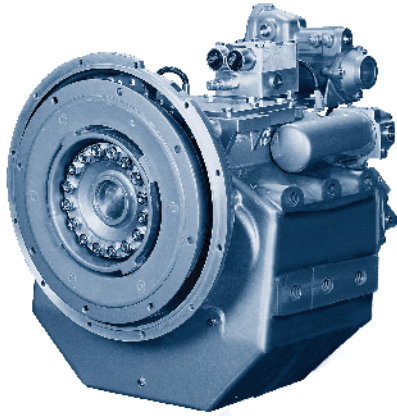

QUICKSHIFT® MARINE TRANSMISSION SERIES OFFERS SUPERIOR MANEUVERING CONTROL

Twin Disc recently introduced a new line of marine transmissions that eliminates the traditional “clunky” shifting characteristics and low speed limitations of conventional marine transmissions.

Until now, large diesel-powered boats could not effectively maintain vessel control below five knots. Reducing engine RPMs that low would likely stall the engine.

Using a proprietary shifting technology, the QuickShift® marine transmission instantly applies power to the driveline at low torque when shifting from neutral to full ahead or full reverse. It senses the amount of power applied and the corresponding torque resistance. It then cushions driveline shock and optimizes the power to the driveshaft to smoothly overcome that resistance within milliseconds. The result is a steep but smooth power curve, whether you go full bore or just nudge the throttle.

The QuickShift® offers pleasure craft and commercial boat operators a distinct advantage for docking and other low speed activities. The QuickShift's® unique ability to regulate engine torque at extremely low speeds allows slowing props down to 50 RPMs or less. This affords controllable maneuvering at slower speeds than even conventional trolling-type transmissions.

Such low speed control in conjunction with extremely fast, jolt-free shifts — even from forward to reverse — greatly facilitates precision handling situations, saving time and improving vessel performance and productivity. In addition, the QuickShift® line, with its extraordinarily smooth shift characteristics, will reduce wear and tear on engine, drive train and crew. Check out the growing line of Twin Disc QuickShift® marine transmissions. It will definitely exceed your expectations in marine transmission performance.

QUICKSHIFT®
You've got to feel it to believe it.

PLEASURE CRAFT RATINGS FOR STANDARD & QUICKSHIFT® MARINE TRANSMISSIONS



Model	Drawing Number	SAE Housing	Ratios	KILOWATTS (HORSEPOWER)			Maximum Speed (rpm)	Dry Weight (kg (lb))
				@ 2300 RPM	@ 2800 RPM	@ 3200 RPM		
MG-340	IT101317501	5, BW	1.45 2.00 2.60	26 (35) 21 (28) 17 (23)	26 (35) 26 (35) 21 (28)	26 (35) 26 (35) 23 (31)	4500	9 (20)
MG-360	IT101318505	5, BW	1.55 2.00 2.45 2.83	40 (54) 36 (48) 29 (39) 24 (32)	50 (67) 44 (59) 35 (47) 29 (39)	56 (75) 50 (67) 40 (54) 33 (44)	5000	14 (31)
MG-5005 A	IT345ATD0001	3, 4, 5	1.54 2.00 2.47	83 (111) 67 (90) 50 (67)	101 (136) 82 (110) 60 (81)	110 (148) 93 (125) 70 (94)	4500	25 (55)
MG-5012 SC	IT1013079B01	3, 4, BW	1.52 2.09 2.40 2.78	123 (165) 106 (142) 94 (126) 82 (110)	149 (200) 129 (173) 115 (154) 100 (134)	171 (229) 148 (198) 131 (176) 114 (153)	4500	53 (117)
MG-5020 SC	IT1013049B01	3, 4, BW	1.50, 2.04 2.50 2.94	181 (242) 145 (194) 123 (165)	220 (295) 176 (236) 150 (201)	251 (337) 201 (270) 171 (229)	4000	75 (165)
MG-5025 A	IT1013170	3, 4, BW	1.52, 2.09 2.40	115 (154) 100 (134)	140 (188) 123 (165)	160 (215) 140 (188)	4500	36 (79)
MG-5055 A	IT101316101	3, 4, BW	1.53, 2.08 2.60	214 (287) 144 (193)	261 (350) 176 (236)	298 (400) 201 (270)	4000	54 (119)
				@ 2300 RPM	@ 2500 RPM	@ 2800 RPM		
MG-5011 SC*	PX-10270	3, 4, BW	1.11, 1.27, 1.50, 2.00 2.44	164 (220) 145 (195)	177 (237) 157 (210)	186 (250) 168 (225)	4400	49 (109)
MG-5011 A*	PX-9999	3, 4, BW	1.44, 1.90 2.39	164 (220) 145 (195)	177 (237) 157 (210)	186 (250) 168 (225)	4400	49 (109)
MG-5011 IV*	PX-10290	3, 4, BW	1.14, 1.54, 2.06 2.51	164 (220) 145 (195)	177 (237) 157 (210)	186 (250) 168 (225)	4400	77 (170)
MG-5050 SC*	PX-12700	1, 2, 3, 4 SPEC. #3	1.00, 1.23, 1.53, 1.71, 2.04 2.45 3.00	226 (303) 226 (303) 200 (268)	245 (329) 233 (312) 213 (286)	272 (365) 261 (350) 231 (310)	3300	86 (189)
MG-5050 A*	PX-12730	1, 2, 3, 4 SPEC. #3	1.12, 1.26, 1.50, 1.80, 2.04 2.50	226 (303) 200 (268)	245 (329) 219 (294)	272 (365) 239 (320)	3300	80 (176)
MG-5050 RV*	PX-8760	—	1.12, 1.26, 1.50, 1.80, 2.04 2.50	226 (303) 200 (268)	245 (329) 219 (294)	272 (365) 239 (320)	3300	73 (160)
MG-5061 SC*	PX-11650/A	1, 2, 3 SPEC. #3	1.15, 1.48, 1.77, 2.00 2.43 3.00	283 (380) 263 (353) 245 (329)	308 (413) 286 (384) 266 (357)	354 (463) 321 (430) 298 (400)	3300	98 (215)
MG-5061 A*	PX-11640/A	1, 2, 3 SPEC. #3	1.13, 1.28, 1.54, 1.75, 2.00 2.47	283 (380) 263 (353)	308 (413) 286 (384)	354 (463) 321 (430)	3300	95 (210)
MG-5061 V*	PX-8735	—	1.13, 1.28, 1.54, 1.75, 2.00 2.47	283 (380) 263 (353)	308 (413) 286 (384)	354 (463) 321 (430)	3300	86 (190)
MG-5062 V*	PX-11660/A	1, 2, 3 SPEC. #3	1.19, 1.53, 1.83 2.07, 2.51	283 (380) 263 (353)	313 (420) 286 (384)	354 (475) 321 (430)	3300	142 (312)
MGX-5065 SC	PX-12410	1, 2, 3 SPEC. #3	1.08, 1.26, 1.47, 1.72, 2.04 2.43	393 (527) 368 (493)	425 (570) 400 (536)	474 (636) 448 (601)	3300	111 (244)
MGX-5065 A	PX-12370	1, 2, 3 SPEC. #3	1.08, 1.26, 1.47, 1.72, 2.04 2.43	393 (527) 368 (493)	425 (570) 400 (536)	474 (636) 448 (601)	3300	111 (244)
MG-5065 SC	PX-11480	1, 2, 3 SPEC. #3	1.08, 1.26, 1.47, 1.72, 2.04 2.43	393 (527) 368 (493)	425 (570) 400 (536)	474 (636) 448 (601)	3300	111 (244)
MG-5065 A	PX-11165	1, 2, 3 SPEC. #3	1.08, 1.26, 1.47, 1.72, 2.04 2.43	393 (527) 368 (493)	425 (570) 400 (536)	474 (636) 448 (601)	3300	111 (244)

Important – See rating definitions, application information, and torsional compatibility notices on pages 1 and 2.
Ratings shown are in SAE Horsepower (HP). Metric Horsepower equals SAE times 1.014.
Weights are approximate and include flywheel housing adapter and flexible input coupling.

* Consult Twin Disc for gasoline engine ratings.

**PLEASURE CRAFT RATINGS FOR STANDARD &
QUICKSHIFT® MARINE TRANSMISSIONS (Continued)**



Model	Drawing Number	SAE Housing	Ratios	KILOWATTS (HORSEPOWER)			Maximum Speed (rpm)	Dry Weight (kg (lb))
				@ 2300 RPM	@ 2500 RPM	@ 2800 RPM		
MGX-5075 SC	PX-12620	1, 2, 3 SPEC. #3	1.06, 1.22, 1.33, 1.53, 1.77, 2.05 2.53 2.88	423 (567) 380 (510) 373 (500)	455 (610) 410 (550) 403 (540)	503 (675) 453 (607) 434 (582)	3500	122 (268)
MGX-5075 A	PX-12610	1, 2, 3 SPEC. #3	1.06, 1.22, 1.33, 1.53, 1.77, 2.05 2.53 2.88	423 (567) 380 (510) 373 (500)	455 (610) 410 (550) 403 (540)	503 (675) 453 (607) 434 (582)	3500	122 (268)
MGX-5075 IV	PX-12630	1, 2, 3 SPEC. #3	1.03, 1.30, 1.49, 1.72, 1.99, 2.46	392 (526)	423 (567)	468 (628)	3500	150 (330)
MG-5075 SC	PX-11876	1, 2, 3 SPEC. #3	0.80, 0.92, 1.01, 1.16	380 (510)	410 (550)	453 (607)	3000	122 (268)
MG-5075 SC	PX-10680/A	1, 2, 3 SPEC. #3	1.06, 1.22, 1.33, 1.53, 1.77, 2.05 2.53 2.88	423 (567) 380 (510) 373 (500)	455 (610) 410 (550) 403 (540)	503 (675) 453 (607) 434 (582)	3500	122 (268)
MG-5075 A	PX-10700/A	1, 2, 3 SPEC. #3	1.06, 1.22, 1.33, 1.53, 1.77, 2.05 2.53 2.88	423 (567) 380 (510) 373 (500)	455 (610) 410 (550) 403 (540)	503 (675) 453 (607) 434 (582)	3500	122 (268)
MG-5075 IV	PX-11530-A	1, 2, 3 SPEC. #3	1.03, 1.30, 1.49, 1.72, 1.99, 2.46	392 (526)	423 (567)	468 (628)	3500	150 (330)
				@ 2100 RPM	@ 2300 RPM	@ 2500 RPM		
MG-5085 SC	PX-9260-B/C	1, 2, 3 SPEC. #3	1.05, 1.22, 1.42, 1.76 1.96 2.33	416 (558) 374 (502) 343 (460)	433 (580) 410 (550) 365 (490)	459 (615) 445 (597) 388 (520)	3200	120 (265)
MG-5085 A	PX-9360-B/C	1, 2, 3 SPEC. #3	1.05, 1.22, 1.47, 1.72 2.04 2.43	416 (558) 374 (502) 343 (460)	433 (580) 410 (550) 365 (490)	459 (615) 445 (597) 388 (520)	3200	123 (270)
MG-5082 SC	PX-11250-A	1, 2	1.06, 1.33, 1.53, 1.77, 2.05 2.53 2.88	490 (657) 462 (620) 428 (574)	522 (700) 492 (660) 447 (600)	543 (728) 521 (699) 465 (624)	3200	135 (298)
MG-5082 A	PX-11040-B	1, 2	1.06, 1.33, 1.53, 1.77, 2.05 2.53 2.88	490 (657) 462 (620) 428 (574)	530 (710) 492 (660) 447 (600)	543 (728) 521 (699) 465 (624)	3200	135 (298)
MGX-5086 SC	PX-12600	1, 2	1.06, 1.33, 1.53, 1.77, 2.05 2.53 2.88	490 (657) 462 (620) 428 (574)	522 (700) 492 (660) 447 (600)	543 (728) 521 (699) 465 (624)	3200	135 (298)
MGX-5086 A	PX-12290	1, 2	1.06, 1.33, 1.53, 1.77, 2.05 2.53 2.88	490 (657) 462 (620) 428 (574)	530 (710) 492 (660) 447 (600)	543 (728) 521 (699) 465 (624)	3200	135 (298)
MG-5091 SC	PX-10016	1, 2	1.17, 1.45, 1.71, 2.04 2.45 2.95	480 (643) 433 (580) 409 (548)	522 (700) 474 (635) 447 (600)	539 (723) 500 (670) 470 (630)	3000	220 (485)
MG-5090 A	PX-10015	1, 2	1.45, 1.73, 1.96 2.43	484 (649) 433 (580)	530 (710) 474 (635)	539 (723) 500 (670)	3000	216 (475)
MGX-5095 SC	PX-12480	1, 2	1.15, 1.27, 1.47, 1.71, 2.00, 2.46 2.95	544 (730) 510 (684)	597 (800) 560 (751)	634 (850) 608 (815)	3000	190 (419)
MGX-5095 A	PX-12360	1, 2	1.28, 1.52, 1.81, 2.04 2.48	560 (751) 521 (699)	597 (800) 560 (751)	634 (850) 599 (803)	3000	185 (407)
MGX-5095 RV	PX-12550	—	1.28, 1.52, 1.81, 2.04 2.48	560 (751) 521 (699)	597 (800) 560 (751)	634 (850) 599 (803)	3000	178 (392)
MG-5095 SC	PX-11535	1, 2	1.15, 1.27, 1.47, 1.71, 2.00, 2.46	544 (730) 510 (684)	597 (800) 560 (751)	634 (850) 608 (815)	3000	190 (419)
MG-5095 A	PX-11495	1, 2	1.28, 1.52, 1.81, 2.04 2.48	560 (751) 521 (699)	597 (800) 560 (751)	634 (850) 599 (803)	3000	185 (407)
MG-5095 RV	PX-11600	—	1.28, 1.52, 1.81, 2.04 2.48	560 (751) 521 (699)	597 (800) 560 (751)	634 (850) 599 (803)	3000	178 (392)

Important – See rating definitions, application information, and torsional compatibility notices on pages 1 and 2.
Ratings shown are in SAE Horsepower (HP). Metric Horsepower equals SAE times 1.014.
Weights are approximate and include flywheel housing adapter and flexible input coupling.

PLEASURE CRAFT RATINGS FOR STANDARD & QUICKSHIFT® MARINE TRANSMISSIONS (Continued)



Model	Drawing Number	SAE Housing	Ratios	KILOWATTS (HORSEPOWER)			Maximum Speed (rpm)	Dry Weight (kg (lb))
				@ 2100 RPM	@ 2300 RPM	@ 2500 RPM		
MGX-5114 SC	PX-12490	1	0.93, 1.02, 1.12, 1.50, 1.74, 2.04, 2.54 3.00	619 (830) 528 (708)	673 (900) 578 (775)	716 (960) 629 (843)	2800 for 0.93:1 3000 for others	203 (447)
MGX-5114 SC-HD	PX-12860	1	1.50, 1.74, 2.04, 2.54 3.00	619 (830) 528 (708)	673 (900) 578 (775)	716 (960) 629 (843)	3000	270 (595)
MGX-5114 DC	PX-12170	1	3.28, 3.43, 4.17 4.59 4.86	619 (830) 579 (776) 567 (760)	673 (900) 634 (850) 604 (810)	701 (940) 679 (911) 634 (850)	3000	360 (793)
MGX-5114 A	1024390	1, 2	1.03, 1.20, 1.48, 1.75, 1.92 2.04, 2.50	619 (830)	673 (900)	701 (940)	3000	206 (455)
MGX-5114 RV	PX-11850	—	1.03, 1.20, 1.48, 1.75, 1.92 2.04, 2.50	619 (830)	673 (900)	701 (940)	3000	198 (435)
MGX-5114 IV	PX-12510	1, 2	1.05, 1.23, 1.52, 1.80, 1.97 2.57	619 (830) 599 (803)	673 (900) 649 (870)	701 (940) 677 (908)	3000	270 (595)
MG-5114 SC	PX-9785-B	1	0.93, 1.02, 1.12, 1.50, 1.74, 2.04, 2.54 3.00	619 (830) 528 (708)	673 (900) 578 (775)	716 (960) 629 (843)	2800 for 0.93:1 3000 for others	203 (447)
MG-5114 DC	PX-10250-A PX-12195(FS)	1 Ind.	3.28, 3.43, 4.17 4.59 4.86	619 (830) 579 (776) 567 (760)	673 (900) 634 (850) 604 (810)	701 (940) 679 (911) 634 (850)	3000	368 (810)
MG-5114 A	PX-11915	1, 2	1.03, 1.20, 1.48, 1.75, 1.92 2.04, 2.50	619 (830)	673 (900)	701 (940)	3000	206 (455)
MG-5114 RV	PX-9830-A	—	1.03, 1.20, 1.48, 1.75, 1.92 2.04, 2.50	619 (830)	673 (900)	701 (940)	3000	198 (435)
MG-5114 IV	PX-11920	1, 2	1.05, 1.23, 1.52, 1.80, 1.97 2.57	619 (830) 599 (803)	673 (900) 649 (870)	701 (940) 677 (908)	3000	270 (595)
				@ 2100 RPM	@ 2300 RPM	@ 2450 RPM		
MGX-5135 SC	PX-12450	1, 0	1.10, 1.28, 1.48, 1.73, 2.04 2.57 2.90	817 (1096) 734 (984) 668 (896)	895 (1200) 820 (1100) 746 (1000)	954 (1279) 873 (1170) 794 (1065)	2800	300 (661)
MGX-5135 A	PX-12380	1, 0	1.16, 1.25, 1.53, 1.79, 2.00 2.52	817 (1096) 734 (984)	895 (1200) 820 (1100)	954 (1279) 873 (1170)	2800	280 (617)
MGX-5135 RV	PX-12520	—	1.16, 1.25, 1.53, 1.79, 2.00 2.52	817 (1096) 734 (984)	895 (1200) 820 (1100)	954 (1279) 873 (1170)	2800	258 (568)
MG-5135 SC	PX-11590	1, 0	1.10, 1.28, 1.48, 1.73, 2.04 2.57 2.90	817 (1096) 734 (984) 668 (896)	895 (1200) 820 (1100) 746 (1000)	954 (1279) 873 (1170) 794 (1065)	2800	300 (661)
MG-5135 A	PX-11380	1, 0	1.16, 1.25, 1.53, 1.79, 2.00 2.52	817 (1096) 734 (984)	895 (1200) 820 (1100)	954 (1279) 873 (1170)	2800	280 (617)
MG-5135 RV	PX-11945	—	1.16, 1.25, 1.53, 1.79, 2.00 2.52	817 (1096) 734 (984)	895 (1200) 820 (1100)	954 (1279) 873 (1170)	2800	258 (568)
MGX-5145 SC	PX-12460	1, 0	1.03, 1.20, 1.33, 1.48, 1.75, 1.96 2.50	949 (1273) 841 (1128)	1007 (1350) 916 (1228)	1050 (1408) 963 (1291)	2500	325 (716)
MGX-5145 A	PX-12420	1, 0	1.26, 1.48, 1.75, 1.96 2.50	949 (1273) 878 (1177)	1007 (1350) 956 (1282)	1050 (1408) 1004 (1346)	2500	333 (734)
MGX-5145 RV	PX-12530	—	1.26, 1.48, 1.75, 1.96 2.50	949 (1273) 878 (1177)	1007 (1350) 956 (1282)	1050 (1408) 1004 (1346)	2500	295 (650)
MG-5145 SC	PX-10885	1, 0	1.03, 1.20, 1.33, 1.48, 1.75, 1.96 2.50	949 (1273) 841 (1128)	1007 (1350) 916 (1228)	1050 (1408) 963 (1291)	2500	325 (716)
MG-5145 A	PX-10830	1, 0	1.26, 1.48, 1.75, 1.96 2.50	949 (1273) 878 (1177)	1007 (1350) 956 (1282)	1050 (1408) 1004 (1346)	2500	333 (734)
MG-5145 RV	PX-10880	—	1.26, 1.48, 1.75, 1.96 2.50	949 (1273) 878 (1177)	1007 (1350) 956 (1282)	1050 (1408) 1004 (1346)	2500	295 (650)

Important – See rating definitions, application information, and torsional compatibility notices on pages 1 and 2.
Ratings shown are in SAE Horsepower (HP). Metric Horsepower equals SAE times 1.014.
Weights are approximate and include flywheel housing adapter and flexible input coupling.

**PLEASURE CRAFT RATINGS FOR STANDARD &
QUICKSHIFT® MARINE TRANSMISSIONS (Continued)**



Model	Drawing Number	SAE Housing	Ratios	KILOWATTS (HORSEPOWER)			Maximum Speed (rpm)	Dry Weight (kg (lb))
				@ 2100 RPM	@ 2300 RPM	@ 2450 RPM		
MGX-5147 SC	PX-12470-A	1, 0	1.20, 1.33, 1.48, 1.57, 1.75, 1.96 2.50	1070 (1435) 875 (1173)	1142 (1531) 952 (1277)	1195 (1603) 1001 (1342)	2500	325 (716)
MGX-5147 A	PX-12430-A	1, 0	1.26, 1.48, 1.75, 1.96 2.50	1070 (1435) 931 (1248)	1142 (1531) 1014 (1360)	1195 (1603) 1065 (1428)	2500	333 (734)
MGX-5147 RV	PX-12540-A	—	1.26, 1.48, 1.75, 1.96 2.50	1070 (1435) 931 (1248)	1142 (1531) 1014 (1360)	1195 (1603) 1065 (1428)	2500	295 (650)
MG-5202 SC	1016103-C	1, 0 Ind.	1.17, 1.33, 1.53, 1.76, 2.03, 2.48, 2.92 3.48	886 (1188) 742 (995)	969 (1300) 800 (1073)	1019 (1366) 841 (1128)	2750 (2500 at 1.17:1)	587 (1292)
MG-5203 SC	1016249-A	1, 0 Ind.	1.17, 1.33, 1.53, 1.76, 2.03, 2.48, 2.92 3.48	886 (1188) 742 (995)	969 (1300) 800 (1073)	1019 (1366) 841 (1128)	2750 (2500 at 1.17:1)	409 (900)
MG-5204 SC	1016250-B	1, 0 Ind.	1.17, 1.33, 1.53, 1.76, 2.03, 2.48, 2.92 3.48	1029 (1380) 984 (1320)	1104 (1480) 1081 (1450)	1104 (1480) 1081 (1450)	2750 (2500 at 1.17:1)	409 (900)
MG-6449 A	7-37423	1, 0 Ind.	1.51, 1.73, 2.07, 2.44 2.95	1007 (1350) 715 (959)	1104 (1480) 782 (1050)	1104 (1480) 782 (1050)	2500	344 (757)
MG-6449 RV	7-37431-A	—	1.51, 1.73, 2.07, 2.44 2.95	1007 (1350) 715 (959)	1104 (1480) 782 (1050)	1104 (1480) 782 (1050)	2500	325 (716)
MGX-6598 DC	7-40379	1, 0 Ind.	2.46, 3.03, 3.48 3.93 4.43	1335 (1790) 1226 (1644) 1070 (1435)	1462 (1961) 1343 (1801) 1172 (1572)	1557 (2088) 1399 (1876) 1249 (1674)	2500	580 (1278)
MGX-6599 SC	7-40384	1, 0 Ind.	1.07, 1.30, 1.50, 1.66 1.74, 1.97, 2.04, 2.19 2.45 2.82	1326 (1778) 1295 (1737) 1226 (1644) 1056 (1416)	1452 (1947) 1418 (1902) 1343 (1801) 1156 (1550)	1518 (2036) 1510 (2024) 1431 (1919) 1232 (1652)	2500	492 (1084)
MGX-6599 A	7-40263	1, 0 Ind.	1.34, 1.51, 1.74, 2.03, 2.24 2.48 2.80	1295 (1737) 1226 (1644) 1056 (1416)	1418 (1902) 1343 (1801) 1156 (1550)	1510 (2024) 1431 (1919) 1232 (1652)	2500	488 (1075)
MGX-6599 RV	7-40336	—	1.34, 1.51, 1.74, 2.03, 2.24 2.48 2.80	1295 (1737) 1226 (1644) 1056 (1416)	1418 (1902) 1343 (1801) 1156 (1550)	1510 (2024) 1431 (1919) 1232 (1652)	2500	468 (1031)
MG-6600 DC	7-36712-A	0 Ind.	3.30, 4.11 4.68, 4.72 5.21 6.05	1319 (1769) 1225 (1643) 1103 (1479) 987 (1324)	1445 (1938) 1342 (1800) 1208 (1620) 1081 (1450)	1539 (2064) 1430 (1918) 1287 (1726) 1152 (1545)	2500	794 (1747)
MGX-6620 SC	7-40337	0 Ind.	1.15, 1.33, 1.53, 1.73 2.03, 2.32, 2.44 2.72	1430 (1918) 1430 (1918) 1342 (1800)	1566 (2100) 1566 (2100) 1470 (1971)	1668 (2237) 1668 (2237) 1556 (2087)	2500	575 (1267)
MGX-6620 A	7-40264	0 Ind.	1.55, 1.72, 2.09, 2.28, 2.42 2.73	1430 (1918) 1373 (1841)	1566 (2100) 1504 (2017)	1668 (2237) 1602 (2148)	2500	580 (1278)
MGX-6620 RV	7-40316	—	1.55, 1.72, 2.09, 2.28, 2.42 2.73	1430 (1918) 1373 (1841)	1566 (2100) 1504 (2017)	1668 (2237) 1602 (2148)	2500	510 (1123)
MGX-6650 SC	1002046	0, 00 Ind.	1.51, 1.88, 2.03, 2.37 2.47, 2.81, 2.93, 3.21	1430 (1918)	1566 (2100)	1602 (2148)	2300 (1.51–2.37) 2500 (2.47–3.21)	1001 (2205)
MGX-6690 SC	1020674	0, 00 Ind.	1.51, 1.88, 2.03, 2.37 2.47, 2.81, 2.93, 3.21	1534 (2057)	1680 (2253)	1790 (2400)	2300 (1.51–2.37) 2500 (2.47–3.21)	1001 (2205)
MGX-6848 SC	1020675	0, 00	1.51, 1.88, 2.03, 2.37 2.47 2.58, 2.93 3.21	1864 (2500) 1864 (2500) 1891 (2536) 1526 (2046)	2028 (2720) 2028 (2720) 1891 (2536) 1653 (2217)	— 2147 (2879) 2001 (2682) 1748 (2343)	2300 (1.51–2.37) 2500 (2.47–3.21)	1001 (2205)

Important – See rating definitions, application information, and torsional compatibility notices on pages 1 and 2.
Ratings shown are in SAE Horsepower (HP). Metric Horsepower equals SAE times 1.014.
Weights are approximate and include flywheel housing adapter and flexible input coupling.

**PLEASURE CRAFT RATINGS FOR STANDARD &
QUICKSHIFT® MARINE TRANSMISSIONS (Continued)**



Model	Drawing Number	SAE Housing	Ratios	KILOWATTS (HORSEPOWER)			Maximum Speed (rpm)	Dry Weight (kg (lb))
				@ 1600 RPM	@ 1800 RPM	@ 2100 RPM		
MG-6984 SC	7-37008	Ind. 0 00	1.18, 1.54, 2.06, 2.29, 2.52 2.92 3.25 3.43	1693 (2270)	1905 (2555)	2222 (2980)	2100	1192 (2628)
	7-37481			1648 (2210)	1854 (2486)	2163 (2900)		
	P-71034-B			1466 (1966)	1649 (2211)	1924 (2580)		
				1364 (1829)	1534 (2057)	1790 (2400)		
MG-6984 A	7-37028	Ind. 0 00	1.48, 1.97, 2.50 2.79 2.93	1693 (2270)	1905 (2555)	2222 (2980)	2100	909 (2000)
	P-71093			1682 (2256)	1892 (2537)	2207 (2960)		
	P-71094			1642 (2202)	1847 (2477)	2155 (2890)		
MG-6984 RV	7-37042	—	1.48, 1.97, 2.50 2.79 2.93	1693 (2270)	1905 (2555)	2222 (2980)	2100	909 (2000)
				1682 (2256)	1892 (2537)	2207 (2960)		
				1642 (2202)	1847 (2477)	2155 (2890)		
MG-61242 SC	7-37017	Ind.	1.16, 1.52, 2.08, 2.47 2.96	2176 (2918)	2448 (3283)	2856 (3830)	2100	1050 (2310)
				2091 (2804)	2353 (3155)	2745 (3681)		
MG-61242 A	7-37046	Ind.	1.42, 2.07, 2.44 2.93	2176 (2918)	2448 (3283)	2856 (3830)	2100	1105 (2431)
				2074 (2781)	2333 (3129)	2722 (3650)		
MG-61242 RV	7-37049	—	1.42, 2.07, 2.44 2.93	2176 (2918)	2448 (3283)	2856 (3830)	2100	1105 (2431)
				2074 (2781)	2333 (3129)	2722 (3650)		

Important – See rating definitions, application information, and torsional compatibility notices on pages 1 and 2.
Ratings shown are in SAE Horsepower (HP). Metric Horsepower equals SAE times 1.014.
Weights are approximate and include flywheel housing adapter and flexible input coupling.

LIGHT DUTY RATINGS FOR STANDARD & QUICKSHIFT® MARINE TRANSMISSIONS



Model	Drawing Number	SAE Housing	Ratios	KILOWATTS (HORSEPOWER)			Maximum Speed (rpm)	Dry Weight (kg (lb))
				@ 2300 RPM	@ 2500 RPM	@ 2800 RPM		
MG-5011 SC*	PX-10270	3, 4, BW	1.11, 1.27, 1.50, 2.00 2.44	153 (205) 136 (182)	165 (221) 146 (196)	174 (233) 157 (211)	4400	49 (109)
MG-5011 A*	PX-9999	3, 4, BW	1.44, 1.90 2.39	153 (205) 136 (182)	165 (221) 146 (196)	174 (233) 157 (211)	4400	49 (109)
MG-5011 IV*	PX-10290	3, 4, BW	1.14, 1.54, 2.06 2.51	153 (205) 136 (182)	165 (221) 146 (196)	174 (233) 157 (211)	4400	77 (170)
MG-5050 SC*	PX-12700	1, 2, 3, 4 SPEC. #3	1.00, 1.23, 1.53, 1.71, 2.04 2.45 3.00	211 (283) 211 (283) 187 (251)	228 (306) 216 (290) 198 (266)	254 (341) 223 (299) 216 (290)	3300	86 (189)
MG-5050 A*	PX-12730	1, 2, 3, 4 SPEC. #3	1.12, 1.26, 1.50, 1.80, 2.04 2.50	211 (283) 187 (251)	228 (306) 204 (274)	254 (341) 223 (299)	3300	80 (176)
MG-5050 RV*	PX-8760	—	1.12, 1.26, 1.50, 1.80, 2.04 2.50	211 (283) 187 (251)	228 (306) 204 (274)	254 (341) 223 (299)	3300	73 (160)
MG-5061 SC*	PX-11650/A	1, 2, 3 SPEC. #3	1.15, 1.48, 1.77, 2.00 2.43 3.00	265 (355) 246 (330) 229 (307)	288 (386) 268 (360) 248 (333)	323 (433) 300 (402) 279 (374)	3300	98 (215)
MG-5061 A*	PX-11640/A	1, 2, 3 SPEC. #3	1.13, 1.28, 1.54, 1.75 2.00, 2.47	257 (345) 246 (330)	281 (377) 268 (360)	313 (420) 300 (402)	3300	95 (210)
MG-5061 V*	PX-8735	—	1.13, 1.28, 1.54, 1.75 2.00, 2.47	257 (345) 246 (330)	281 (377) 268 (360)	313 (420) 300 (402)	3300	86 (190)
MG-5062 V*	PX-11660/A	1, 2, 3 SPEC. #3	1.19, 1.53, 1.83 2.07, 2.51	265 (355) 246 (330)	292 (392) 268 (360)	331 (444) 300 (402)	3300	142 (312)
MGX-5065 SC	PX-12410	1, 2, 3 SPEC. #3	1.08, 1.26, 1.47, 1.72, 2.04 2.43	376 (504) 351 (471)	407 (546) 381 (511)	453 (607) 428 (574)	3300	111 (244)
MGX-5065 A	PX-12370	1, 2, 3 SPEC. #3	1.08, 1.26, 1.47, 1.72, 2.04 2.43	376 (504) 351 (471)	407 (546) 381 (511)	453 (607) 428 (574)	3300	111 (244)
MG-5065 SC	PX-11480	1, 2, 3 SPEC. #3	1.08, 1.26, 1.47, 1.72, 2.04 2.43	376 (504) 351 (471)	407 (546) 381 (511)	453 (607) 428 (574)	3300	111 (244)
MG-5065 A	PX-11165	1, 2, 3 SPEC. #3	1.08, 1.26, 1.47, 1.72, 2.04 2.43	376 (504) 351 (471)	407 (546) 381 (511)	453 (607) 428 (574)	3300	111 (244)
MGX-5075 SC	PX-12620	1, 2, 3 SPEC. #3	1.06, 1.22, 1.33, 1.53, 1.77, 2.05 2.53 2.88	368 (493) 355 (476) 348 (467)	390 (523) 383 (514) 375 (503)	433 (581) 423 (567) 406 (544)	3500	122 (268)
MGX-5075 A	PX-12610	1, 2, 3 SPEC. #3	1.06, 1.22, 1.33, 1.53, 1.77, 2.05 2.53 2.88	368 (493) 355 (476) 348 (467)	390 (523) 383 (514) 375 (503)	433 (581) 423 (567) 406 (544)	3500	122 (268)
MGX-5075 IV	PX-12630	1, 2, 3 SPEC. #3	1.03, 1.30, 1.49, 1.72, 1.99, 2.46	355 (476)	383 (514)	423 (567)	3500	150 (330)
MG-5075 SC	PX-11876	1, 2, 3 SPEC. #3	0.80, 0.92, 1.01, 1.16	355 (476)	383 (514)	423 (567)	3000	122 (268)
MG-5075 SC	PX-10680/A	1, 2, 3 SPEC. #3	1.06, 1.22, 1.33, 1.53, 1.77, 2.05 2.53 2.88	368 (493) 355 (476) 348 (467)	390 (523) 383 (514) 375 (503)	433 (581) 423 (567) 406 (544)	3500	122 (268)
MG-5075 A	PX-10700/A	1, 2, 3 SPEC. #3	1.06, 1.22, 1.33, 1.53, 1.77, 2.05 2.53 2.88	368 (493) 355 (476) 348 (467)	390 (523) 383 (514) 375 (503)	433 (581) 423 (567) 406 (544)	3500	122 (268)
MG-5075 IV	PX-11530	1, 2, 3 SPEC. #3	1.03, 1.30, 1.49, 1.72, 1.99, 2.46	355 (476)	383 (514)	423 (567)	3500	150 (330)
				@ 2100 RPM	@ 2300 RPM	@ 2500 RPM		
MG-5085 SC	PX-9260-B/C	1, 2, 3 SPEC. #3	1.05, 1.22, 1.42, 1.76 1.96 2.33	389 (522) 348 (467) 321 (430)	404 (542) 383 (514) 342 (459)	429 (575) 416 (558) 362 (485)	3200	120 (265)
MG-5085 A	PX-9360-B/C	1, 2, 3 SPEC. #3	1.05, 1.22, 1.47, 1.72 2.04 2.43	389 (522) 355 (476) 321 (430)	404 (542) 383 (514) 342 (459)	429 (575) 416 (558) 362 (485)	3200	123 (270)

Important - See rating definitions, application information, and torsional compatibility notices on pages 1 and 2.
Ratings shown are in SAE Horsepower (HP). Metric Horsepower equals SAE times 1.014.
Weights are approximate and include flywheel housing adapter and flexible input coupling.

* Consult Twin Disc for gasoline engine ratings.

LIGHT DUTY RATINGS FOR STANDARD & QUICKSHIFT® MARINE TRANSMISSIONS (Continued)



Model	Drawing Number	SAE Housing	Ratios	KILOWATTS (HORSEPOWER)			Maximum Speed (rpm)	Dry Weight (kg (lb))
				@ 2100 RPM	@ 2300 RPM	@ 2500 RPM		
MG-5082 SC	PX-11250-A	1, 2	1.06, 1.33, 1.53, 1.77, 2.05, 2.53 2.88	432 (579) 400 (536)	460 (617) 418 (560)	487 (653) 434 (582)	3200	135 (298)
MG-5082 A	PX-11040-B	1, 2	1.06, 1.33, 1.53, 1.77, 2.05, 2.53 2.88	432 (579) 400 (536)	460 (617) 418 (560)	487 (653) 434 (582)	3200	135 (298)
MGX-5086 SC	PX-12600	1, 2	1.06, 1.33, 1.53, 1.77, 2.05, 2.53 2.88	432 (579) 400 (536)	460 (617) 418 (560)	487 (653) 434 (582)	3200	135 (298)
MGX-5086 A	PX-12290	1, 2	1.06, 1.33, 1.53, 1.77, 2.05, 2.53 2.88	432 (579) 400 (536)	460 (617) 418 (560)	487 (653) 434 (582)	3200	135 (298)
MG-5091 SC	PX-10016	1, 2	1.17, 1.45, 1.71, 2.04 2.45 2.95	429 (575) 404 (542) 382 (512)	471 (632) 442 (593) 418 (561)	495 (664) 467 (626) 439 (589)	3000	220 (485)
MG-5090 A	PX-10015	1, 2	1.45, 1.73, 1.96 2.43	429 (575) 404 (542)	471 (632) 442 (593)	494 (662) 434 (626)	3000	216 (475)
MGX-5095 SC	PX-12480	1, 2	1.15, 1.27, 1.47, 1.71, 2.00, 2.46 2.95	525 (704) 481 (645)	560 (751) 522 (700)	593 (795) 554 (743)	3000	190 (419)
MGX-5095 A	PX-12360	1, 2	1.28, 1.52, 1.81, 2.04 2.48	525 (704) 485 (650)	560 (751) 522 (700)	594 (797) 558 (748)	3000	185 (407)
MGX-5095 RV	PX-12550	—	1.28, 1.52, 1.81, 2.04 2.48	525 (704) 485 (650)	560 (751) 522 (700)	594 (797) 558 (748)	3000	178 (392)
MG-5095 SC	PX-11535	1, 2	1.15, 1.27, 1.47, 1.71, 2.00, 2.46 2.95	525 (704) 481 (645)	560 (751) 522 (700)	593 (795) 554 (743)	3000	190 (419)
MG-5095 A	PX-11495	1, 2	1.28, 1.52, 1.81, 2.04 2.48	525 (704) 485 (650)	560 (751) 522 (700)	594 (797) 558 (748)	3000	185 (407)
MG-5095 RV	PX-11600	—	1.28, 1.52, 1.81, 2.04 2.48	525 (704) 485 (650)	560 (751) 522 (700)	594 (797) 558 (748)	3000	178 (392)
MGX-5114 SC	PX-12490	1	0.93, 1.02, 1.12, 1.50, 1.74 2.04, 2.54 3.00	579 (776) 579 (776) 494 (662)	629 (843) 629 (843) 540 (724)	669 (897) 669 (897) 588 (789)	2800 at .93:1 3000 for others	203 (447)
MGX-5114 SC-HD	PX-12860	1	1.50, 1.74, 2.04, 2.54 3.00	579 (776) 494 (662)	629 (843) 540 (724)	669 (897) 588 (789)	3000	270 (595)
MGX-5114 DC	PX-12170	1	3.28, 3.43, 4.17 4.59 4.86	580 (777) 541 (725) 530 (711)	629 (843) 629 (843) 540 (724)	655 (878) 634 (850) 576 (772)	3000	360 (793)
MGX-5114 A	1024390	1, 2	1.03, 1.20, 1.48, 1.75, 1.92 2.04, 2.50	580 (777)	629 (843)	655 (878)	3000	206 (455)
MGX-5114 RV	PX-11850	—	1.03, 1.20, 1.48, 1.75, 1.92 2.04, 2.50	580 (777)	629 (843)	655 (878)	3000	198 (435)
MGX-5114 IV	PX-12510	1, 2	1.05, 1.23, 1.52, 1.80, 1.97 2.57	580 (777) 560 (751)	629 (843) 607 (814)	655 (878) 632 (848)	3000	270 (595)
MG-5114 SC	PX-9785-B	1	0.93, 1.02, 1.12, 1.50, 1.74, 2.04, 2.54 3.00	579 (776) 494 (662)	629 (843) 540 (724)	669 (897) 588 (789)	2800 at .93:1 3000 for others	203 (447)
MG-5114 DC	PX-10250-A PX-12195(FS)	1 Ind.	3.28, 3.43, 4.17 4.59 4.86	579 (776) 542 (727) 530 (711)	629 (843) 591 (793) 565 (758)	656 (880) 634 (850) 575 (771)	3000	368 (810)
MG-5114 A	PX-11915	1, 2	1.03, 1.20, 1.48, 1.75, 1.92 2.04, 2.50	580 (777)	629 (843)	656 (880)	3000	206 (455)
MG-5114 RV	PX-9830-A	—	1.03, 1.20, 1.48, 1.75, 1.92 2.04, 2.50	580 (777)	629 (843)	656 (880)	3000	198 (435)
MG-5114 IV	PX-11920	1, 2	1.05, 1.23, 1.52, 1.80, 1.97 2.57	580 (777) 560 (751)	629 (843) 607 (814)	656 (880) 632 (848)	3000	270 (595)

Important – See rating definitions, application information, and torsional compatibility notices on pages 1 and 2.
Ratings shown are in SAE Horsepower (HP). Metric Horsepower equals SAE times 1.014.
Weights are approximate and include flywheel housing adapter and flexible input coupling.

LIGHT DUTY RATINGS FOR STANDARD & QUICKSHIFT® MARINE TRANSMISSIONS (Continued)



Model	Drawing Number	SAE Housing	Ratios	KILOWATTS (HORSEPOWER)			Maximum Speed (rpm)	Dry Weight (kg (lb))
				@ 2100 RPM	@ 2300 RPM	@ 2500 RPM		
MGX-5135 SC	PX-12450	1, 0	1.10, 1.28, 1.48, 1.73, 2.04 2.57 2.90	704 (944) 663 (889) 622 (834)	746 (1000) 716 (960) 671 (900)	788 (1057) 768 (1030) 720 (966)	2800	300 (661)
MGX-5135 A	PX-12380	1, 0	1.16, 1.25, 1.53, 1.79, 2.00 2.52	704 (944) 663 (889)	746 (1000) 716 (960)	788 (1057) 768 (1030)	2800	280 (617)
MGX-5135 RV	PX-12520	—	1.16, 1.25, 1.53, 1.79, 2.00 2.52	704 (944) 663 (889)	746 (1000) 716 (960)	788 (1057) 768 (1030)	2800	258 (568)
MG-5135 SC	PX-11590	1, 0	1.10, 1.28, 1.48, 1.73, 2.04 2.57 2.90	704 (944) 663 (889) 622 (834)	746 (1000) 716 (960) 671 (900)	788 (1057) 768 (1030) 720 (966)	2800	300 (661)
MG-5135 A	PX-11380	1, 0	1.16, 1.25, 1.53, 1.79, 2.00 2.52	704 (944) 663 (889)	746 (1000) 716 (960)	788 (1057) 768 (1030)	2800	280 (617)
MG-5135 RV	PX-11945	—	1.16, 1.25, 1.53, 1.79, 2.00 2.52	704 (944) 663 (889)	746 (1000) 716 (960)	788 (1057) 768 (1030)	2800	258 (568)
MGX-5145 SC	PX-12460	1, 0	1.03, 1.20, 1.33, 1.48, 1.75, 1.96 2.50	808 (1084) 759 (1018)	857 (1150) 820 (1100)	906 (1215) 881 (1181)	2500	325 (716)
MGX-5145 A	PX-12420	1, 0	1.26, 1.48, 1.75, 1.96 2.50	808 (1084) 759 (1018)	857 (1150) 820 (1100)	906 (1215) 881 (1181)	2500	333 (734)
MGX-5145 RV	PX-12530	—	1.26, 1.48, 1.75, 1.96 2.50	808 (1084) 759 (1018)	857 (1150) 820 (1100)	906 (1215) 881 (1181)	2500	295 (650)
MG-5145 SC	PX-10885	1, 0	1.03, 1.20, 1.33, 1.48, 1.75, 1.96 2.50	808 (1084) 759 (1018)	857 (1150) 820 (1100)	906 (1215) 881 (1181)	2500	325 (716)
MG-5145 A	PX-10830	1, 0	1.26, 1.48, 1.75, 1.96 2.50	808 (1084) 759 (1018)	857 (1150) 820 (1100)	906 (1215) 881 (1181)	2500	333 (734)
MG-5145 RV	PX-10880	—	1.26, 1.48, 1.75, 1.96 2.50	808 (1084) 759 (1018)	857 (1150) 820 (1100)	906 (1215) 881 (1181)	2500	295 (650)
MGX-5147 SC	PX-12470-A	1, 0	1.20, 1.33, 1.48, 1.57, 1.75, 1.96 2.50	918 (1231) 828 (1110)	974 (1306) 895 (1200)	1028 (1379) 961 (1289)	2500	325 (716)
MGX-5147 A	PX-12430-A	1, 0	1.26, 1.48, 1.75, 1.96 2.50	918 (1231) 828 (1110)	974 (1306) 895 (1200)	1028 (1379) 961 (1289)	2500	333 (734)
MGX-5147 RV	PX-12540-A	—	1.26, 1.48, 1.75, 1.96 2.50	918 (1231) 828 (1110)	974 (1306) 895 (1200)	1028 (1379) 961 (1289)	2500	295 (650)
				@ 1800 RPM	@ 2100 RPM	@ 2300 RPM		
MG-5202 SC	1016103-C	1, 0 Ind.	1.17, 1.33, 1.53, 1.76, 2.03, 2.48, 2.92 3.48	742 (995) 641 (860)	852 (1142) 731 (980)	924 (1239) 789 (1059)	2750	587 (1292)
MG-5203 SC	1016249-A	1, 0 Ind.	1.17, 1.33, 1.53, 1.76, 2.03, 2.48, 2.92 3.48	742 (995) 641 (860)	852 (1142) 731 (980)	924 (1239) 789 (1059)	2750	409 (900)
MG-5204 SC	1016250-B	1, 0 Ind.	1.17, 1.33, 1.53, 1.76, 2.03, 2.48, 2.92 3.48	742 (995) 647 (868)	865 (1160) 764 (1025)	979 (1313) 837 (1122)	2750	409 (900)
MG-6449 A	7-37423	1, 0 Ind.	1.51, 1.73 2.07 2.44 2.95	840 (1126) 795 (1067) 711 (953) 545 (731)	978 (1312) 912 (1223) 805 (1080) 635 (852)	1072 (1437) 974 (1306) 861 (1154) 696 (933)	2500	344 (757)
MG-6449 RV	7-37431-A	—	1.51, 1.73 2.07 2.44 2.95	840 (1126) 795 (1067) 711 (953) 545 (731)	978 (1312) 912 (1223) 805 (1080) 635 (852)	1072 (1437) 974 (1306) 861 (1154) 696 (933)	2500	325 (716)
MGX-6598 DC	7-40379	1, 0 Ind.	2.46, 3.03 3.48 3.93 4.43	1000 (1341) 1000 (1341) 952 (1277) 862 (1156)	1167 (1565) 1155 (1549) 1060 (1421) 990 (1328)	1278 (1714) 1241 (1664) 1131 (1517) 1055 (1415)	2500	580 (1278)
MGX-6599 SC	7-40384	1, 0 Ind.	1.07, 1.30, 1.50, 1.66, 1.74 1.97, 2.04, 2.19 2.45 2.82	1010 (1354) 1001 (1342) 920 (1234) 821 (1101)	1178 (1580) 1167 (1565) 1073 (1439) 955 (1281)	1244 (1668) 1234 (1655) 1164 (1561) 1042 (1397)	2500	492 (1084)

Important - See rating definitions, application information, and torsional compatibility notes on pages 1 and 2.
Ratings shown are in SAE Horsepower (HP). Metric Horsepower equals SAE times 1.014.
Weights are approximate and include flywheel housing adapter and flexible input coupling.

LIGHT DUTY RATINGS FOR STANDARD & QUICKSHIFT® MARINE TRANSMISSIONS (Continued)



Model	Drawing Number	SAE Housing	Ratios	KILOWATTS (HORSEPOWER)			Maximum Speed (rpm)	Dry Weight (kg (lb))
				@ 1800 RPM	@ 2100 RPM	@ 2300 RPM		
MGX-6599 A	7-40263	1, 0 Ind.	1.34, 1.51, 1.74, 2.03, 2.24 2.48 2.80	1092 (1464) 935 (1254) 896 (1202)	1221 (1637) 1091 (1463) 1045 (1401)	1301 (1745) 1195 (1602) 1144 (1534)	2500	488 (1075)
MGX-6599 RV	7-40336	—	1.34, 1.51, 1.74, 2.03, 2.24 2.48 2.80	1092 (1464) 935 (1254) 896 (1202)	1221 (1637) 1091 (1463) 1045 (1401)	1301 (1745) 1195 (1602) 1144 (1534)	2500	468 (1031)
MG-6600 DC	7-36712A	0 Ind.	3.30, 4.11 4.68, 4.72 5.22 6.05	1009 (1353) 926 (1242) 818 (1097) 722 (968)	1177 (1578) 1080 (1448) 953 (1278) 843 (1129)	1289 (1728) 1182 (1585) 1044 (1400) 923 (1237)	2500	794 (1747)
MGX-6620 SC	7-40337	0 Ind.	1.15 1.33, 1.53, 1.73, 2.03 2.32, 2.44 2.72	1109 (1487) 1109 (1487) 1109 (1487) 1080 (1448)	1294 (1735) 1294 (1735) 1294 (1735) 1255 (1683)	1338 (1794) 1417 (1900) 1417 (1900) 1338 (1794)	2500	575 (1267)
MGX-6620 A	7-40264	0 Ind.	1.55, 1.72, 2.09, 2.28, 2.42 2.73	1106 (1483) 1105 (1482)	1294 (1735) 1248 (1674)	1417 (1900) 1330 (1784)	2500	580 (1278)
MGX-6620 RV	7-40316	—	1.55, 1.72, 2.09, 2.28, 2.42 2.73	1106 (1483) 1105 (1482)	1294 (1735) 1248 (1674)	1417 (1900) 1330 (1784)	2500	510 (1123)
MGX-6650 SC	1002046	0, 00 Ind.	1.51, 1.88, 2.03, 2.37 2.47, 2.93, 3.21	1225 (1643)	1417 (1900)	1464 (1963)	2300 (1.51-2.37) 2500 (2.47-3.21)	1001 (2205)
MGX-6690 SC	1020674	0, 00 Ind.	1.51, 1.88, 2.03, 2.37 2.47, 2.93, 3.21	1225 (1643)	1417 (1900)	1464 (1963)	2300 (1.51-2.37) 2500 (2.47-3.21)	1001 (2205)
MGX-6848 SC	1020675	0, 00 Ind.	1.51, 1.88, 2.03, 2.47 2.58, 2.93 3.21	1591 (2134) 1483 (1989) 1297 (1739)	1828 (2451) 1699 (2278) 1485 (1991)	1985 (2662) 1841 (2469) 1609 (2158)	2300 (1.51-2.03) 2500 (2.47-3.21)	1001 (2205)
				@ 1600 RPM	@ 1800 RPM	@ 2100 RPM		
MG-6984 SC	7-37008 7-37481 P-71034-B	Ind. 0 00	1.18, 1.54, 2.06, 2.29, 2.52 2.92 3.25 3.43	1614 (2164) 1528 (2049) 1269 (1702) 1180 (1582)	1816 (2435) 1719 (2305) 1427 (1914) 1328 (1781)	2119 (2842) 2006 (2690) 1665 (2233) 1549 (2077)	2100	1192 (2628)
MG-6984 A	7-37028 P-71093 P-71094	Ind. 0 00	1.48, 1.97 2.50 2.79 2.93	1602 (2148) 1552 (2081) 1536 (2060) 1512 (2028)	1802 (2416) 1746 (2341) 1728 (2317) 1701 (2281)	2102 (2819) 2037 (2732) 2016 (2703) 1984 (2661)	2100	909 (2000)
MG-6984 RV	7-37042	—	1.48, 1.97 2.50 2.79 2.93	1602 (2148) 1552 (2081) 1536 (2060) 1512 (2028)	1802 (2416) 1746 (2341) 1728 (2317) 1701 (2281)	2102 (2819) 2037 (2732) 2016 (2703) 1984 (2661)	2100	909 (2000)
MG-61242 SC	7-37017	Ind.	1.16, 1.52, 2.08 2.47 2.96	2064 (2768) 2207 (2691) 1950 (2615)	2322 (3114) 2258 (3028) 2193 (2941)	2709 (3633) 2634 (3532) 2559 (3432)	2100	1050 (2310)
MG-61242 A	7-37046	Ind.	1.42, 2.07 2.44 2.93	2090 (2803) 2207 (2691) 1950 (2615)	2351 (3153) 2258 (3028) 2193 (2941)	2743 (3678) 2634 (3532) 2559 (3432)	2100	1105 (2431)
MG-61242 RV	7-37049	—	1.42, 2.07 2.44 2.93	2090 (2803) 2207 (2691) 1950 (2615)	2351 (3153) 2258 (3028) 2193 (2941)	2743 (3678) 2634 (3532) 2559 (3432)	2100	1105 (2431)

Important - See rating definitions, application information, and torsional compatibility notices on pages 1 and 2.
Ratings shown are in SAE Horsepower (HP). Metric Horsepower equals SAE times 1.014.
Weights are approximate and include flywheel housing adapter and flexible input coupling.

Consult Twin Disc on light duty ratings for models MG-514C SC/DC, MGX-516 DC, MGX-5170 DC, MG-520-1HP, MGX-5222 DC, MGX-5225 DC, MGX-5321, MG-540, MGX-5600 and other deep ratio units not listed.

INTERMEDIATE DUTY RATINGS FOR STANDARD & QUICKSHIFT® MARINE TRANSMISSIONS



Model	Drawing Number	SAE Housing	Ratios	KILOWATTS (HORSEPOWER)			Maximum Speed (rpm)	Dry Weight (kg (lb))
				@ 2100 RPM	@ 2500 RPM	@ 2800 RPM		
MG-340	IT101317501	5, BW	1.45 2.00 2.60	24 (32) 17 (23) 13 (17)	26 (35) 20 (27) 15 (20)	26 (35) 23 (31) 18 (24)	4500	9 (20)
MG-360	IT101318505	5, BW	1.55 2.00 2.45 2.83	31 (42) 28 (38) 23 (31) 19 (26)	36 (48) 33 (44) 29 (39) 22 (30)	41 (55) 37 (50) 31 (42) 25 (34)	5000	14 (31)
MG-5005 A	IT345ATD0001	3, 4, 5	1.54, 2.00 2.47	47 (63) 35 (47)	56 (75) 41 (55)	63 (85) 47 (63)	4500	25 (55)
MG-5012 SC	IT1013079801	3, 4, BW	1.52 2.09 2.40 2.78	93 (124) 81 (108) 72 (96) 62 (84)	110 (148) 96 (129) 85 (115) 74 (100)	124 (166) 108 (144) 96 (128) 83 (111)	4500	53 (117)
MG-5020 SC	IT1013049801	3, 4, BW	1.50, 2.04 2.50 2.94	134 (179) 107 (144) 93 (124)	159 (214) 128 (171) 110 (148)	178 (239) 143 (192) 124 (166)	4000	75 (165)
MG-5025 A	IT1013170	3, 4, BW	1.52, 2.09 2.40	81 (109) 69 (93)	97 (130) 82 (110)	108 (145) 92 (123)	4500	36 (79)
MG-5055 A	IT101316101	3, 4, BW	1.53, 2.08 2.60	147 (197) 99 (135)	175 (235) 118 (160)	196 (263) 132 (179)	4000	54 (119)
MG-5010 DC	PX-9400	3, 4, BW	3.00 3.52 4.00	87 (117) 77 (103) 67 (90)	104 (140) 92 (123) 80 (107)	112 (150) 103 (138) 89 (120)	4000	75 (165)
MG-5011 SC	PX-10270	3, 4, BW	1.11, 1.27, 1.50, 2.00 2.44	112 (150) 92 (124)	123 (165) 112 (150)	127 (170) 119 (160)	4400	49 (109)
MG-5011 A	PX-9999	3, 4, BW	1.44, 1.90 2.39	112 (150) 103 (138)	123 (165) 112 (150)	127 (170) 123 (165)	4400	49 (109)
MG-5011 IV	PX-10290	3, 4, BW	1.14, 1.54, 2.06 2.51	112 (150) 92 (124)	123 (165) 112 (150)	127 (170) 119 (160)	4400	77 (170)
MG-5050 SC	PX-12700	1, 2, 3, 4 SPEC. #3	1.00, 1.23, 1.53, 1.71, 2.04, 2.45 3.00	157 (211) 142 (190)	187 (251) 170 (228)	209 (280) 194 (260)	3300	86 (189)
MG-5050 A	PX-12730	1, 2, 3, 4 SPEC. #3	1.12, 1.26, 1.50, 1.80, 2.04, 2.50	157 (211)	187 (251)	209 (280)	3300	80 (176)
MG-5050 RV	PX-8760	—	1.12, 1.26, 1.50, 1.80, 2.04, 2.50	157 (211)	187 (251)	209 (280)	3300	73 (160)
MG-506-1	XA7022-A XA7048-A	1, 2, 3 1, 2, 3	1.09, 1.50, 1.97 2.50, 2.96	121 (162) 121 (162)	144 (193) 144 (193)	160 (215) 160 (215)	3000 3000	100 (220) 102 (224)
MG-5061 SC	PX-11650/-A	1, 2, 3 SPEC. #3	1.15, 1.48, 1.77, 2.00, 2.43, 3.00	201 (270)	239 (320)	261 (350)	3300	98 (215)
MG-5061 A	PX-11640/-A	1, 2, 3 SPEC. #3	1.13, 1.28, 1.54, 1.75, 2.00, 2.47	201 (270)	239 (320)	261 (350)	3300	95 (210)
MG-5061 V	PX-8735	—	1.13, 1.28, 1.54, 1.75, 2.00, 2.47	201 (270)	239 (320)	261 (350)	3300	95 (210)
MG-5062 V	PX-11660/-A	1, 2, 3 SPEC. #3	1.19, 1.53, 1.83, 2.07, 2.51	201 (270)	239 (320)	261 (350)	3300	142 (312)
MGX-5065 SC	PX-12410	1, 2, 3 SPEC. #3	1.08, 1.26, 1.47, 1.72, 2.04 2.43	279 (374) 254 (341)	329 (441) 302 (405)	367 (492) 338 (453)	3300	111 (244)
MGX-5065 A	PX-12370	1, 2, 3 SPEC. #3	1.08, 1.26, 1.47, 1.72, 2.04 2.43	279 (374) 254 (341)	329 (441) 302 (405)	367 (492) 338 (453)	3300	111 (244)
MG-5065 SC	PX-11480	1, 2, 3 SPEC. #3	1.08, 1.26, 1.47, 1.72, 2.04 2.43	279 (374) 254 (341)	329 (441) 302 (405)	367 (492) 338 (453)	3300	111 (244)
MG-5065 A	PX-11165	1, 2, 3 SPEC. #3	1.08, 1.26, 1.47, 1.72, 2.04 2.43	279 (374) 254 (341)	329 (441) 302 (405)	367 (492) 338 (453)	3300	111 (244)

Important – See rating definitions, application information, and torsional compatibility notices on pages 1 and 2.
Ratings shown are in SAE Horsepower (HP). Metric Horsepower equals SAE times 1.014.
Weights are approximate and include flywheel housing adapter and flexible input coupling.

INTERMEDIATE DUTY RATINGS FOR STANDARD & QUICKSHIFT® MARINE TRANSMISSIONS (Continued)



Model	Drawing Number	SAE Housing	Ratios	KILOWATTS (HORSEPOWER)			Maximum Speed (rpm)	Dry Weight (kg (lb))
				@ 2100 RPM	@ 2500 RPM	@ 2800 RPM		
MGX-5075 SC	PX-12620	1, 2, 3 SPEC. #3	1.06, 1.22, 1.33, 1.53, 1.77, 2.05 2.53 2.88	283 (380) 268 (360) 261 (350)	310 (416) 298 (400) 287 (385)	324 (434) 313 (420) 306 (410)	3500	122 (268)
MGX-5075 A	PX-12610	1, 2, 3 SPEC. #3	1.06, 1.22, 1.33, 1.53, 1.77, 2.05 2.53 2.88	283 (380) 268 (360) 261 (350)	310 (416) 298 (400) 287 (385)	324 (434) 313 (420) 306 (410)	3500	122 (268)
MGX-5075 IV	PX-12630	1, 2, 3 SPEC. #3	1.03, 1.30, 1.49, 1.72, 1.99, 2.46	268 (360)	298 (400)	313 (420)	3500	150 (330)
MG-5075 SC	PX-11876	1, 2, 3 SPEC. #3	0.80, 0.92, 1.01, 1.16	268 (360)	298 (400)	313 (420)	3000	122 (268)
MG-5075 SC	PX-10680/A	1, 2, 3 SPEC. #3	1.06, 1.22, 1.33, 1.53, 1.77, 2.05 2.53 2.88	283 (380) 268 (360) 261 (350)	310 (416) 298 (400) 287 (385)	324 (434) 313 (420) 306 (410)	3500	122 (268)
MG-5075 A	PX-10700/A	1, 2, 3 SPEC. #3	1.06, 1.22, 1.33, 1.53, 1.77, 2.05 2.53 2.88	283 (380) 268 (360) 261 (350)	310 (416) 298 (400) 287 (385)	324 (434) 313 (420) 306 (410)	3500	122 (268)
MG-5075 IV	PX-11530	1, 2, 3 SPEC. #3	1.03, 1.30, 1.49, 1.72, 1.99, 2.46	268 (360)	298 (400)	313 (420)	3500	150 (330)
MG-509	X-9816-F	1, 2	1.45, 2.00 2.48 2.95 3.39	235 (315) 235 (315) 216 (290) 165 (220)	273 (366)* 273 (366)* 244 (327)* 190 (255)*	300 (400)* 300 (400)* 265 (355)* 210 (280)*	3000*	259 (572)
	X-9835	1, 2	3.83, 4.50 4.95	235 (315) 180 (242)	279 (374)* 213 (285)*	311 (417)* 235 (315)*	3000*	323 (712)
MG-5085 SC	PX-9260-B/C	1, 2, 3 SPEC. #3	1.05, 1.22, 1.42, 1.76, 1.96 2.33	287 (385) 268 (360)	332 (445) 302 (405)	365 (490) 328 (440)	3200	120 (265)
MG-5085 A	PX-9360-B/C	1, 2, 3 SPEC. #3	1.05, 1.22, 1.47, 1.72, 2.04 2.43	287 (385) 268 (360)	332 (445) 302 (405)	365 (490) 328 (440)	3200	123 (270)
MG-5082 SC	PX-11250-A	1, 2	1.06, 1.33, 1.53, 1.77, 2.05, 2.53 2.88	351 (471) 340 (456)	396 (531) 384 (515)	428 (574) 415 (557)	3200	135 (298)
MG-5082 A	PX-11040-B	1, 2	1.06, 1.33, 1.53, 1.77, 2.05, 2.53 2.88	351 (471) 340 (456)	396 (531) 384 (515)	428 (574) 415 (557)	3200	135 (298)
MGX-5086 SC	PX-12600	1, 2	1.06, 1.33, 1.53, 1.77, 2.05, 2.53 2.88	351 (471) 340 (456)	396 (531) 384 (515)	428 (574) 415 (557)	3200	135 (298)
MGX-5086 A	PX-12290	1, 2	1.06, 1.33, 1.53, 1.77, 2.05, 2.53 2.88	351 (471) 340 (456)	396 (531) 384 (515)	428 (574) 415 (557)	3200	135 (298)
MG-5091 SC	PX-10016	1	1.17, 1.45, 1.71, 2.04 2.45, 2.95 3.33	354 (475) 336 (450) 268 (360)	403 (540) 374 (501) 309 (415)	425 (570) 403 (540) 346 (464)	3000	220 (485)
MG-5091 DC	1002155	1	3.82 4.50 5.05	321 (431) 298 (400) 251 (336)	377 (506) 350 (470) 298 (400)	420 (563) 384 (515) 334 (448)	3000	297 (655)
MG-5090 A	PX-10015	1, 2	1.45, 1.73, 1.96 2.43	343 (460) 321 (430)	365 (490) 343 (460)	382 (512) 359 (481)	3000	216 (475)
				@ 1800 RPM	@ 2100 RPM	@ 2300 RPM		
MGX-5095 SC	PX-12480	1, 2	1.15, 1.27, 1.47, 1.71, 2.00, 2.46 2.95	368 (493) 332 (445)	410 (550) 380 (510)	438 (587) 412 (552)	3000	190 (419)
MGX-5095 A	PX-12360	1, 2	1.28, 1.52, 1.81, 2.04 2.48	367 (492) 336 (451)	410 (550) 380 (510)	438 (587) 409 (548)	3000	185 (407)
MGX-5095 RV	PX-12550	—	1.28, 1.52, 1.81, 2.04 2.48	367 (492) 336 (451)	410 (550) 380 (510)	438 (587) 409 (548)	3000	178 (392)

Important – See rating definitions, application information, and torsional compatibility notices on pages 1 and 2.
Ratings shown are in SAE Horsepower (HP). Metric Horsepower equals SAE times 1.014.
Weights are approximate and include flywheel housing adapter and flexible input coupling.

* SAE-14" A6911 driving ring has a 2150 rpm maximum speed.

INTERMEDIATE DUTY RATINGS FOR STANDARD & QUICKSHIFT® MARINE TRANSMISSIONS (Continued)



Model	Drawing Number	SAE Housing	Ratios	KILOWATTS (HORSEPOWER)			Maximum Speed (rpm)	Dry Weight (kg (lb))
				@ 1800 RPM	@ 2100 RPM	@ 2300 RPM		
MG-5095 SC	PX-11535	1, 2	1.15, 1.27, 1.47, 1.71, 2.00, 2.46 2.95	368 (493) 332 (445)	410 (550) 380 (510)	438 (587) 412 (552)	3000	190 (419)
MG-5095 A	PX-11495	1, 2	1.28, 1.52, 1.81, 2.04 2.48	367 (492) 336 (451)	410 (550) 380 (510)	438 (587) 409 (548)	3000	185 (407)
MG-5095 RV	PX-11600	—	1.28, 1.52, 1.81, 2.04 2.48	367 (492) 336 (451)	410 (550) 380 (510)	438 (587) 409 (548)	3000	178 (392)
MGX-5114 SC	PX-12490	1	0.93, 1.02, 1.12, 1.50, 1.74, 2.04 2.54 3.00	448 (601) 410 (550) 380 (510)	504 (676) 466 (625) 451 (605)	552 (740) 500 (671) 492 (660)	2800 at .93:1 3000 for others	203 (447)
MGX-5114 SC-HD	PX-12860	1	1.50, 1.74, 2.04 2.54 3.00	448 (601) 410 (550) 380 (510)	504 (676) 466 (625) 451 (605)	552 (740) 500 (671) 492 (660)	3000	270 (595)
MGX-5114 DC	PX-12170	1	3.28, 3.43, 4.17 4.59 4.86	431 (580) 388 (520) 375 (503)	504 (676) 448 (601) 429 (575)	537 (720) 477 (640) 463 (621)	3000	360 (793)
MGX-5114 A	1024390	1, 2	1.03, 1.20, 1.48, 1.75, 1.92, 2.04 2.50	404 (542) 351 (471)	466 (625) 400 (536)	504 (676) 433 (581)	3000	206 (455)
MGX-5114 RV	PX-11850	—	1.03, 1.20, 1.48, 1.75, 1.92, 2.04 2.50	404 (542) 351 (471)	466 (625) 400 (536)	504 (676) 433 (581)	3000	198 (435)
MGX-5114 IV	PX-12510	1, 2	1.05, 1.23, 1.52, 1.80, 1.97 2.57	404 (542) 351 (471)	466 (625) 400 (536)	504 (676) 433 (581)	3000	270 (595)
MG-5114 SC	PX-9785-B	1	0.93, 1.02, 1.12, 1.50, 1.74, 2.04 2.54 3.00	448 (601) 410 (550) 380 (510)	504 (676) 466 (625) 451 (605)	552 (740) 507 (680) 492 (660)	2800 at .93:1 3000 for others	203 (447)
MG-5114 SC-HD	PX-11962	1	1.50, 1.74, 2.04 2.54 3.00	448 (601) 410 (550) 380 (510)	504 (676) 466 (625) 451 (605)	552 (740) 507 (680) 492 (660)	3000	270 (595)
MG-5114 DC	PX-10250-A PX-12195 (FS)	1 Ind.	3.28, 3.43, 4.17 4.59 4.86	431 (578) 388 (520) 375 (503)	504 (676) 448 (601) 429 (575)	537 (720) 477 (640) 463 (621)	3000	368 (810)
MG-5114 A	PX-11915	1, 2	1.03, 1.20, 1.48, 1.75, 1.92, 2.04 2.50	404 (542) 351 (471)	466 (625) 400 (536)	504 (676) 433 (581)	3000	206 (455)
MG-5114 RV	PX-9830-A	—	1.03, 1.20, 1.48, 1.75, 1.92, 2.04 2.50	404 (542) 351 (471)	466 (625) 400 (536)	504 (676) 433 (581)	3000	198 (435)
MG-5114 IV	PX-11920	1, 2	1.05, 1.23, 1.52, 1.80, 1.97 2.57	404 (542) 351 (471)	466 (625) 400 (536)	504 (676) 433 (581)	3000	270 (595)
MGX-5135 SC	PX-12450	1, 0	1.10, 1.28, 1.48, 1.73, 2.04, 2.57 2.90	529 (709) 493 (661)	560 (751) 522 (700)	600 (805) 560 (751)	2800	300 (661)
MGX-5135 A	PX-12380	1, 0	1.16, 1.25, 1.53, 1.79, 2.00, 2.52	529 (709)	560 (751)	600 (805)	2800	280 (617)
MGX-5135 RV	PX-12520	—	1.16, 1.25, 1.53, 1.79, 2.00, 2.52	529 (709)	560 (751)	600 (805)	2800	258 (568)
MG-5135 SC	PX-11590	1, 0	1.10, 1.28, 1.48, 1.73, 2.04, 2.57 2.90	529 (709) 493 (661)	560 (751) 522 (700)	600 (805) 560 (751)	2800	300 (661)
MG-5135 A	PX-11380	1, 0	1.16, 1.25, 1.53, 1.79, 2.00, 2.52	529 (709)	560 (751)	600 (805)	2800	280 (617)
MG-5135 RV	PX-11945	—	1.16, 1.25, 1.53, 1.79, 2.00, 2.52	529 (709)	560 (751)	600 (805)	2800	258 (568)
MG-514C SC	X-9784-C	1, 0 (14" only)	1.51, 2.00, 2.50, 3.00 3.50	326 (437) 288 (386)	380 (510) 336 (450)	418 (560) 365 (490)	2500	524 (1155)
MG-514C DC	X-9786-C	1, 0 (14" only)	4.13, 4.50, 5.16 6.00	F326 (437) R307 (412) 283 (380)	F380 (510) R358 (480) 330 (442)	F418 (560) R378 (507) 359 (481)	2500	658 (1450)

Important - See rating definitions, application information, and torsional compatibility notices on pages 1 and 2.
Ratings shown are in SAE Horsepower (HP). Metric Horsepower equals SAE times 1.014.
Weights are approximate and include flywheel housing adapter and flexible input coupling.

INTERMEDIATE DUTY RATINGS FOR STANDARD & QUICKSHIFT® MARINE TRANSMISSIONS (Continued)



Model	Drawing Number	SAE Housing	Ratios	KILOWATTS (HORSEPOWER)			Maximum Speed (rpm)	Dry Weight (kg (lb))
				@ 1800 RPM	@ 2100 RPM	@ 2300 RPM		
MGX-5145 SC	PX-12460	1, 0	1.03, 1.20, 1.33, 1.48, 1.75, 1.96 2.50	698 (936) 587 (787)	746 (1000) 671 (900)	836 (1121) 726 (974)	2500	325 (716)
MGX-5145 A	PX-12420	1, 0	1.26, 1.48, 1.75, 1.96 2.50	698 (936) 587 (787)	746 (1000) 671 (900)	836 (1121) 726 (974)	2500	333 (734)
MGX-5145 RV	PX-12530	—	1.26, 1.48, 1.75, 1.96 2.50	698 (936) 587 (787)	746 (1000) 671 (900)	836 (1121) 726 (974)	2500	295 (650)
MG-5145 SC	PX-10885	1, 0	1.03, 1.20, 1.33, 1.48, 1.75, 1.96 2.50	698 (936) 587 (787)	746 (1000) 671 (900)	836 (1121) 726 (974)	2500	325 (716)
MG-5145 A	PX-10830	1, 0	1.26, 1.48, 1.75, 1.96 2.50	698 (936) 587 (787)	746 (1000) 671 (900)	836 (1121) 726 (974)	2500	333 (734)
MG-5145 RV	PX-10880	—	1.26, 1.48, 1.75, 1.96 2.50	698 (936) 587 (787)	746 (1000) 671 (900)	836 (1121) 726 (974)	2500	295 (650)
MGX-5147 SC	PX-12470-A	1, 0	1.20, 1.33, 1.48, 1.57, 1.75, 1.96 2.50	753 (1010) 615 (825)	806 (1081) 702 (941)	903 (1211) 760 (1019)	2500	325 (716)
MGX-5147 A	PX-12430-A	1, 0	1.26, 1.48, 1.75, 1.96 2.50	753 (1010) 615 (825)	806 (1081) 702 (941)	903 (1211) 760 (1019)	2500	333 (734)
MGX-5147 RV	PX-12540-A	—	1.03, 1.20, 1.33, 1.48, 1.75, 1.96 2.50	753 (1010) 615 (825)	806 (1081) 702 (941)	903 (1211) 760 (1019)	2500	295 (650)
MGX-516 DC	1023380 (14" only)	1, 0	3.06 3.50 4.04 4.52 5.05 6.00	530 (711) 518 (695) 494 (662) 484 (649) 468 (628) 419 (562)	573 (768) 549 (736) 521 (699) 510 (684) 492 (660) 470 (630)	594 (797) 569 (763) 540 (724) 526 (705) 508 (681) 498 (668)	2500	717 (1580)
MGX-5170 DC	1023382	1, 0	3.12, 3.54, 4.06, 4.50, 5.03, 5.95 6.53, 6.95	537 (720) 467 (626)	578 (775) 545 (731)	578 (775) 561 (752)	2500	850 (1872)
MG-520-1HP	XA-7255-B	0	4.49, 5.00, 6.11 7.00 7.42	718 (963) 667 (894) 623 (835)	837 (1122) 764 (1025) 714 (957)	917 (1230) 828 (1110) 774 (1038)	2500	1559 (3436)
MG-5202 SC	1016103-C	1, 0 Ind.	1.17, 1.33, 1.53, 1.76, 2.03, 2.48, 2.92 3.48	630 (845)	720 (966)	778 (1043)	2750 (2500 at 1.17:1)	587 (1292)
MG-5203 SC	1016249-A	1, 0 Ind.	1.17, 1.33, 1.53, 1.76, 2.03, 2.48, 2.92 3.48	630 (845)	720 (966)	778 (1043)	2750 (2500 at 1.17:1)	409 (900)
MG-5204 SC	1016250-B	1, 0 Ind.	1.17, 1.33, 1.53, 1.76, 2.03, 2.48, 2.92 3.48	727 (975) 630 (845)	858 (1151) 720 (966)	969 (1299) 781 (1047)	2750 (2500 at 1.17:1)	409 (900)
MGX-5222 DC	1022822-A	1, 0 Ind.	4.03, 4.59, 5.04, 6.10, 6.55, 6.96	630 (845)	720 (966)	778 (1043)	2500	1046 (2304)
MGX-5225 DC	1022825-A	1, 0 Ind.	4.03, 4.59, 5.04, 5.57, 6.10	727 (975)	858 (1151)	869 (1165)	2500	1046 (2304)
MGX-5321 DC	1022203-B	0, 00 Ind.	3.35, 4.06, 4.42, 4.96, 5.46, 5.96 6.39	1044 (1400) 893 (1198)	1163 (1560) 1022 (1371)	1178 (1580) 1108 (1486)	2400	1754 (3864)
MG-540 (with rubber block drive)	X-9882-C	0 00, Ind.	1.93, 2.58, 2.90 3.26 3.91 4.10, 4.60 5.17 6.18 7.00 7.47	986 (1322) 902 (1210) 832 (1116) 986 (1322) 886 (1188) 832 (1116) 700 (939) 667 (894)	1055 (1415)* 1005 (1348)* 931 (1248)* 1055 (1415)* 988 (1325)* 931 (1248)* 779 (1045)* 742 (995)*	— 1156 (1550)* 1040 (1395)* — 1119 (1501)* 1040 (1395)* 895 (1200)* 850 (1140)*	1900* 2100* 2400* 1900* 2100* 2400* 2400* 2400*	2105 (4640)

Important - See rating definitions, application information, and torsional compatibility notices on pages 1 and 2.
Ratings shown are in SAE Horsepower (HP). Metric Horsepower equals SAE times 1.014.
Weights are approximate and include flywheel housing adapter and flexible input coupling.

* The max. input speed is 1650 rpm if MG-540 - SAE #00 is used with 21" rubber block drive.

**INTERMEDIATE DUTY RATINGS FOR STANDARD &
QUICKSHIFT® MARINE TRANSMISSIONS (Continued)**



Model	Drawing Number	SAE Housing	Ratios	KILOWATTS (HORSEPOWER)			Maximum Speed (rpm)	Dry Weight (kg (lb))
				@ 1600 RPM	@ 1800 RPM	@ 2100 RPM		
MG-540 (with flexible coupling)	X-9882-C	0 00, Ind.	1.93, 2.58, 2.90, 3.26	1049 (1407)	1180 (1582)	—	1900	2105 (4640)
			3.91	893 (1198)	1011 (1356)	1193 (1600)	2400	
			4.10, 4.60	1049 (1407)	1180 (1582)	—	1900	
			5.17	1038 (1392)	1168 (1566)	1362 (1826)	2100	
			6.18	867 (1163)	975 (1307)	1138 (1526)	2400	
			7.00	766 (1027)	861 (1155)	1005 (1348)	2400	
			7.47	718 (963)	808 (1084)	943 (1265)	2400	
MG-5506	00D005604	0, 00 Ind.	4.03, 4.55, 4.96, 5.44 6.00	1323 (1774) 1197 (1605)	1489 (1998) 1347 (1806)	—	2000	2200 (4846)
MGX-5600	1022780	0, 00 Ind.	2.53, 2.98, 3.51, 4.03	1602 (2148)	1805 (2421)	2105 (2823)	2100	3132 (6890)
			4.63, 5.04	1602 (2148)	1805 (2421)	2095 (2809)		
			5.76	1598 (2143)	1760 (2360)	1770 (2374)		
			6.04	1353 (1814)	1502 (2014)	1717 (2302)		
				@ 1800 RPM	@ 2100 RPM	@ 2300 RPM		
MG-6449 A	7-37423	1, 0 Ind.	1.51, 1.73	769 (1031)	897 (1203)	958 (1285)	2500	344 (757)
			2.07	639 (857)	746 (1000)	794 (1065)		
			2.44	555 (744)	647 (868)	692 (928)		
			2.95	496 (665)	577 (774)	617 (828)		
MG-6449 RV	7-37431-A	—	1.51, 1.73	769 (1031)	897 (1203)	958 (1285)	2500	325 (716)
			2.07	639 (857)	746 (1000)	794 (1065)		
			2.44	555 (744)	647 (868)	692 (928)		
			2.95	496 (665)	577 (774)	617 (828)		
MGX-6598 DC	7-40379	1, 0 Ind.	2.46, 3.03	882 (1183)	1000 (1341)	1067 (1431)	2500	580 (1278)
			3.48	849 (1139)	945 (1267)	1008 (1352)		
			3.93	774 (1038)	861 (1155)	918 (1231)		
			4.43	722 (968)	804 (1078)	857 (1149)		
MGX-6599 SC	7-40384	1, 0 Ind.	1.07, 1.30, 1.50, 1.66, 1.74, 1.97, 2.04	862 (1156)	960 (1287)	1023 (1372)	2500	492 (1084)
			2.19, 2.45	844 (1132)	940 (1261)	1002 (1344)		
			2.82	728 (976)	811 (1088)	864 (1159)		
MGX-6599 A	7-40263	1, 0 Ind.	1.34, 1.51, 1.74, 2.03, 2.24	890 (1193)	992 (1330)	1057 (1417)	2500	488 (1075)
			2.48	841 (1128)	937 (1257)	999 (1340)		
			2.80	815 (1093)	908 (1218)	967 (1297)		
MGX-6599 RV	7-40336	—	1.34, 1.51, 1.74, 2.03, 2.24	890 (1193)	992 (1330)	1057 (1417)	2500	468 (1031)
			2.48	841 (1128)	937 (1257)	999 (1340)		
			2.80	815 (1093)	908 (1218)	967 (1297)		
MG-6600 DC	7-36712-A	0 Ind.	3.30	819 (1098)	955 (1281)	1046 (1403)	2500	794 (1747)
			4.11	819 (1098)	955 (1281)	1018 (1365)		
			4.68, 4.72	777 (1042)	906 (1215)	966 (1295)		
			5.21	693 (929)	809 (1085)	886 (1188)		
			6.05	617 (828)	719 (964)	788 (1057)		
MGX-6620 SC	7-40337	0 Ind.	1.15, 1.33, 1.53, 1.73	1047 (1404)	1166 (1564)	1191 (1597)	2500	575 (1267)
			2.03	1025 (1375)	1142 (1531)	1184 (1588)		
			2.32	1019 (1366)	1136 (1523)	1184 (1588)		
			2.44	987 (1324)	1100 (1475)	1172 (1572)		
			2.72	915 (1227)	1019 (1366)	1086 (1456)		
MGX-6620 A	7-40264	0 Ind.	1.55, 1.72, 2.09	1103 (1479)	1234 (1655)	1315 (1763)	2500	580 (1278)
			2.28, 2.42	1028 (1379)	1145 (1535)	1220 (1636)		
			2.73	910 (1220)	1014 (1360)	1080 (1448)		
MGX-6620 RV	7-40316	—	1.55, 1.72, 2.09	1103 (1479)	1234 (1655)	1315 (1763)	2500	510 (1123)
			2.28, 2.42	1028 (1379)	1145 (1535)	1220 (1636)		
			2.73	910 (1220)	1014 (1360)	1080 (1448)		

Important – See rating definitions, application information, and torsional compatibility notices on pages 1 and 2.
Ratings shown are in SAE Horsepower (HP). Metric Horsepower equals SAE times 1.014.
Weights are approximate and include flywheel housing adapter and flexible input coupling.

INTERMEDIATE DUTY RATINGS FOR STANDARD & QUICKSHIFT® MARINE TRANSMISSIONS (Continued)



Model	Drawing Number	SAE Housing	Ratios	KILOWATTS (HORSEPOWER)			Maximum Speed (rpm)	Dry Weight (kg (lb))
				@ 1800 RPM	@ 2100 RPM	@ 2300 RPM		
MGX-6650 SC	1002046	0, 00 Ind.	1.51, 1.88, 2.03, 2.37 2.47, 2.93, 3.21	1069 (1434)	1268 (1700)	1386 (1859)	2300 (1.51–2.37) 2500 (2.47–3.21)	1001 (2205)
MGX-6690 SC	1020674	0, 00 Ind.	1.51, 1.88, 2.03, 2.37, 2.47 2.93 3.21	1201 (1611) 1201 (1611) 1201 (1611)	1380 (1851) 1318 (1767) 1280 (1716)	1438 (1928) 1386 (1859) 1386 (1859)	2300 (1.51–2.37) 2500 (2.47–3.21)	1001 (2205)
MGX-6848 SC	1020675	0, 00 Ind.	1.51, 1.88, 2.03, 2.47, 2.58, 2.93 3.21	1342 (1800) 1269 (1702)	1566 (2100) 1453 (1948)	1715 (2300) 1575 (2112)	2300 (1.51–2.03) 2500 (2.47–3.21)	1001 (2205)
				@ 1600 RPM	@ 1800 RPM	@ 2100 RPM		
MG-6984 SC	7-37008 7-37481 P-71034-B	Ind. 0 00	1.18, 1.54, 2.06, 2.29, 2.52, 2.92 3.25 3.43	1470 (1971) 1244 (1668) 1000 (1341)	1654 (2218) 1399 (1876) 1125 (1509)	1929 (2587) 1632 (2189) 1313 (1761)	2100	1192 (2628)
MG-6984 A	7-37028 P-71093 P-71094	Ind. 0 00	1.48, 1.97, 2.50, 2.79 2.93	1504 (2017) 1462 (1961)	1692 (2269) 1645 (2206)	1974 (2647) 1919 (2573)	2100	909 (2000)
MG-6984 RV	7-37042	—	1.48, 1.97, 2.50, 2.79 2.93	1504 (2017) 1462 (1961)	1692 (2269) 1645 (2206)	1974 (2647) 1919 (2573)	2100	909 (2000)
MG-61242 SC	7-37017	Ind.	1.16, 1.52, 2.08 2.47 2.96	2001 (2683) 1960 (2628) 1949 (2614)	2251 (3019) 2205 (2957) 2193 (2941)	2626 (3521) 2571 (3448) 2559 (3432)	2100	1050 (2310)
MG-61242 A	7-37046	Ind.	1.42, 2.07 2.44, 2.93	2078 (2787) 1949 (2614)	2338 (3135) 2193 (2941)	2728 (3658) 2559 (3432)	2100	1105 (2431)
MG-61242 RV	7-37049	—	1.42, 2.07 2.44, 2.93	2078 (2787) 1949 (2614)	2338 (3135) 2193 (2941)	2728 (3658) 2559 (3432)	2100	1105 (2431)

MEDIUM DUTY RATINGS FOR STANDARD & QUICKSHIFT® MARINE TRANSMISSIONS



Model	Drawing Number	SAE Housing	Ratios	KILOWATTS (HORSEPOWER)			Maximum Speed (rpm)	Dry Weight (kg (lb))
				@ 1800 RPM	@ 2100 RPM	@ 2300 RPM		
MG-5011 SC	PX-10270	3, 4, BW	1.11, 1.27, 1.50, 2.00 2.44	74 (99) 57 (77)	82 (110) 74 (99)	90 (121) 82 (110)	4400	49 (109)
MG-5011 A	PX-9999	3, 4, BW	1.44, 1.90 2.39	74 (99) 66 (89)	82 (110) 74 (99)	90 (121) 82 (110)	4400	49 (109)
MG-5011 IV	PX-10290	3, 4, BW	1.14, 1.54, 2.06 2.51	74 (99) 57 (77)	82 (110) 66 (89)	90 (121) 74 (99)	4400	77 (170)
MG-5050 SC	PX-12700	1, 2, 3, 4 SPEC. #3	1.00, 1.23, 1.53, 1.71, 2.04, 2.45 3.00	115 (154) 102 (137)	128 (172) 119 (160)	140 (188) 133 (178)	3300	86 (189)
MG-5050 A	PX-12730	1, 2, 3, 4 SPEC. #3	1.12, 1.26, 1.50, 1.80, 2.04, 2.50	115 (154)	128 (172)	140 (188)	3300	80 (176)
MG-5050 RV	PX-8760	—	1.12, 1.26, 1.50, 1.80, 2.04, 2.50	115 (154)	128 (172)	140 (188)	3300	73 (160)
MG-5061 SC	PX-11650/A	1, 2, 3 SPEC. #3	1.15, 1.48, 1.77, 2.00, 2.43 3.00	135 (181) 126 (169)	157 (211) 147 (197)	171 (229) 160 (215)	3300	98 (215)
MG-5061 A	PX-11640/A	1, 2, 3 SPEC. #3	1.13, 1.28, 1.54, 1.75, 2.00 2.47	135 (181) 126 (169)	157 (211) 147 (197)	171 (229) 160 (215)	3300	95 (210)
MG-5061 V	PX-8735	—	1.13, 1.28, 1.54, 1.75, 2.00 2.47	135 (181) 126 (169)	157 (211) 147 (197)	171 (229) 160 (215)	3300	95 (210)
MG-5062 V	PX-11660/A	1, 2, 3 SPEC. #3	1.19, 1.53, 1.83, 2.07, 2.51	135 (181)	157 (211)	171 (229)	3300	142 (312)
MGX-5065 SC	PX-12410	1, 2, 3 SPEC. #3	1.08, 1.26, 1.47, 1.72, 2.04 2.43	227 (304) 208 (279)	262 (351) 243 (326)	285 (382) 266 (357)	3300	111 (244)
MGX-5065 A	PX-12370	1, 2, 3 SPEC. #3	1.08, 1.26, 1.47, 1.72, 2.04 2.43	227 (304) 208 (279)	262 (351) 243 (326)	285 (382) 266 (357)	3300	111 (244)
MG-5065 SC	PX-11480	1, 2, 3 SPEC. #3	1.08, 1.26, 1.47, 1.72, 2.04 2.43	227 (304) 208 (279)	262 (351) 243 (326)	285 (382) 266 (357)	3300	111 (244)
MG-5065 A	PX-11165	1, 2, 3 SPEC. #3	1.08, 1.26, 1.47, 1.72, 2.04 2.43	227 (304) 208 (279)	262 (351) 243 (326)	285 (382) 266 (357)	3300	111 (244)
MGX-5075 SC	PX-12620	1, 2, 3 SPEC. #3	1.06, 1.22, 1.33, 1.53, 1.77, 2.05 2.53, 2.88	205 (275)	230 (308)	246 (330)	3500	122 (268)
MGX-5075 A	PX-12610	1, 2, 3 SPEC. #3	1.06, 1.22, 1.33, 1.53, 1.77, 2.05 2.53, 2.88	205 (275)	230 (308)	246 (330)	3500	122 (268)
MGX-5075 IV	PX-12630	1, 2, 3 SPEC. #3	1.03, 1.30, 1.49, 1.72, 1.99, 2.46	205 (275)	230 (308)	246 (330)	3500	150 (330)
MG-5075 SC	PX-10680/A	1, 2, 3 SPEC. #3	1.06, 1.22, 1.33, 1.53, 1.77, 2.05 2.53, 2.88	205 (275)	230 (308)	246 (330)	3500	122 (268)
MG-5075 A	PX-10700/A	1, 2, 3 SPEC. #3	1.06, 1.22, 1.33, 1.53, 1.77, 2.05 2.53, 2.88	205 (275)	230 (308)	246 (330)	3500	122 (268)
MG-5075 IV	PX-11530	1, 2, 3 SPEC. #3	1.03, 1.30, 1.49, 1.72, 1.99, 2.46	205 (275)	230 (308)	246 (330)	3500	150 (330)
MG-5085 SC	PX-9260-B/C	1, 2, 3 SPEC. #3	1.05, 1.22, 1.42, 1.76, 1.96 2.33	250 (335) 225 (302)	279 (375) 254 (341)	295 (396) 271 (363)	3200	120 (265)
MG-5085 A	PX-9360-B/C	1, 2, 3 SPEC. #3	1.05, 1.22, 1.47, 1.72, 2.04 2.43	250 (335) 217 (291)	279 (375) 248 (333)	295 (396) 268 (360)	3200	123 (270)
MG-5082 SC	PX-11250-A	1, 2	1.06, 1.33, 1.53, 1.77, 2.05, 2.53 2.88	301 (404) 273 (366)	336 (451) 313 (420)	350 (469) 331 (444)	3200	135 (298)
MG-5082 A	PX-11040-B	1, 2	1.06, 1.33, 1.53, 1.77, 2.05, 2.53 2.88	301 (404) 273 (366)	336 (451) 313 (420)	350 (469) 331 (444)	3200	135 (298)
MGX-5086 SC	PX-12600	1, 2	1.06, 1.33, 1.53, 1.77, 2.05, 2.53 2.88	301 (404) 273 (366)	336 (451) 313 (420)	350 (469) 331 (444)	3200	135 (298)
MGX-5086 A	PX-12290	1, 2	1.06, 1.33, 1.53, 1.77, 2.05, 2.53 2.88	301 (404) 273 (366)	336 (451) 313 (420)	350 (469) 331 (444)	3200	135 (298)

Important – See rating definitions, application information, and torsional compatibility notices on pages 1 and 2.
Ratings shown are in SAE Horsepower (HP). Metric Horsepower equals SAE times 1.014.
Weights are approximate and include flywheel housing adapter and flexible input coupling.

MEDIUM DUTY RATINGS FOR STANDARD & QUICKSHIFT® MARINE TRANSMISSIONS (Continued)



Model	Drawing Number	SAE Housing	Ratios	KILOWATTS (HORSEPOWER)			Maximum Speed (rpm)	Dry Weight kg (lb)
				@ 1800 RPM	@ 2100 RPM	@ 2300 RPM		
MG-5091 SC	PX-10016	1, 2	1.17, 1.45, 1.71, 2.04 2.45, 2.95 3.33	274 (368) 265 (355) 219 (293)	317 (425) 308 (413) 254 (340)	347 (465) 330 (443) 274 (368)	3000	220 (485)
MG-5091 DC	1002155	1, 2	3.82, 4.50 5.05	262 (351) 210 (281)	303 (406) 245 (328)	330 (443) 268 (359)	3000	297 (655)
MG-5090 A	PX-10015	1, 2	1.45, 1.73, 1.96 2.43	267 (358) 250 (335)	309 (415) 291 (390)	321 (430) 302 (405)	3000	216 (475)
MGX-5095 SC	PX-12480	1, 2	1.15, 1.27, 1.47, 1.71, 2.00, 2.46 2.95	336 (451) 319 (428)	374 (502) 360 (483)	399 (535) 385 (516)	3000	190 (419)
MGX-5095 A	PX-12360	1, 2	1.28, 1.52, 1.81, 2.04, 2.48	319 (428)	358 (480)	385 (516)	3000	185 (407)
MGX-5095 RV	PX-12550	—	1.28, 1.52, 1.81, 2.04, 2.48	319 (428)	358 (480)	385 (516)	3000	178 (392)
MG-5095 SC	PX-11535	1, 2	1.15, 1.27, 1.47, 1.71, 2.00, 2.46 2.95	336 (451) 319 (428)	374 (502) 360 (483)	399 (535) 385 (516)	3000	190 (419)
MG-5095 A	PX-11495	1, 2	1.28, 1.52, 1.81, 2.04, 2.48	319 (428)	358 (480)	385 (516)	3000	185 (407)
MG-5095 RV	PX-11600	—	1.28, 1.52, 1.81, 2.04, 2.48	319 (428)	358 (480)	385 (516)	3000	178 (392)
MGX-5114 SC	PX-12490	1	0.93, 1.02, 1.12, 1.50, 1.74 2.04, 2.54 3.00	394 (528) 394 (528) 361 (484)	451 (605) 451 (605) 410 (550)	489 (656) 489 (656) 443 (595)	2800 at .93:1 3000 for others	203 (447)
MGX-5114 SC-HD	PX-12860	1	1.50, 1.74 2.04, 2.54 3.00	394 (528) 394 (528) 361 (484)	451 (605) 451 (605) 410 (550)	489 (656) 489 (656) 443 (595)	3000	270 (595)
MGX-5114 DC	PX-12170	1	3.28, 3.43, 4.17, 4.59, 4.86	361 (484)	419 (562)	437 (586)	3000	360 (793)
MGX-5114 A	1024390	1, 2	1.03, 1.20, 1.48, 1.75, 1.92, 2.04 2.50	357 (479) 338 (453)	407 (546) 385 (516)	440 (590) 417 (559)	3000	206 (455)
MGX-5114 RV	PX-11850	—	1.03, 1.20, 1.48, 1.75, 1.92, 2.04 2.50	357 (479) 338 (453)	407 (546) 385 (516)	440 (590) 417 (559)	3000	198 (435)
MGX-5114 IV	PX-12510	1, 2	1.05, 1.23, 1.52, 1.80, 1.97 2.57	357 (479) 338 (453)	407 (546) 385 (516)	440 (590) 417 (559)	3000	270 (595)
MG-5114 SC	PX-9785-B	1	0.93, 1.02, 1.12, 1.50, 1.74 2.04, 2.54 3.00	394 (528) 394 (528) 361 (484)	451 (605) 451 (605) 410 (550)	489 (656) 489 (656) 443 (595)	2800 at .93:1 3000 for others	203 (447)
MG-5114 SC-HD	PX-11962	1	1.50, 1.74 2.04, 2.54 3.00	394 (528) 394 (528) 361 (484)	451 (605) 451 (605) 410 (550)	489 (656) 489 (656) 443 (595)	3000	270 (595)
MG-5114 DC	PX-10250-A PX-12195(FS)	1 Ind.	3.28, 3.43, 4.17, 4.59, 4.86	361 (484)	419 (562)	437 (586)	3000	368 (810)
MG-5114 A	PX-11915	1, 2	1.03, 1.20, 1.48, 1.75, 1.92, 2.04 2.50	357 (479) 338 (453)	407 (546) 385 (516)	440 (590) 417 (559)	3000	206 (455)
MG-5114 RV	PX-9830-A	—	1.03, 1.20, 1.48, 1.75, 1.92, 2.04 2.50	357 (479) 338 (453)	407 (546) 385 (516)	440 (590) 417 (559)	3000	198 (435)
MG-5114 IV	PX-11920	1, 2	1.05, 1.23, 1.52, 1.80, 1.97 2.57	357 (479) 338 (453)	407 (546) 385 (516)	440 (590) 417 (559)	3000	270 (595)
MG-514C SC	X-9784-C	1, 0 (14" only)	1.51, 2.00, 2.50 3.00 3.50	* 328 (440) 306 (410) 283 (380)	* 358 (480) 336 (450) 313 (420)	* 377 (505) 354 (475) 332 (445)	2500	524 (1155)
MG-514C DC	X-9786-C	1, 4 (14" only)	4.13, 4.50, 5.16 6.04	298 (400) 272 (365)	334 (448) 309 (415)	358 (480) 347 (465)	2500	658 (1450)

MEDIUM DUTY RATINGS FOR STANDARD & QUICKSHIFT® MARINE TRANSMISSIONS (Continued)



Model	Drawing Number	SAE Housing	Ratios	KILOWATTS (HORSEPOWER)			Maximum Speed (rpm)	Dry Weight (kg (lb))
				@ 1600 RPM	@ 1800 RPM	@ 2100 RPM		
MGX-5135 SC	PX-12450	1, 0	1.10, 1.28, 1.48, 1.73, 2.04, 2.57 2.90	447 (599) 413 (554)	485 (650) 448 (601)	542 (727) 500 (671)	2800	300 (661)
MGX-5135 A	PX-12380	1, 0	1.16, 1.25, 1.53, 1.79, 2.00, 2.52	447 (599)	485 (650)	542 (727)	2800	280 (617)
MGX-5135 RV	PX-12520	—	1.16, 1.25, 1.53, 1.79, 2.00, 2.52	447 (599)	485 (650)	542 (727)	2800	258 (568)
MG-5135 SC	PX-11590	1, 0	1.10, 1.28, 1.48, 1.73, 2.04, 2.57 2.90	447 (599) 413 (554)	485 (650) 448 (601)	542 (727) 500 (671)	2800	300 (661)
MG-5135 A	PX-11380	1, 0	1.16, 1.25, 1.53, 1.79, 2.00, 2.52	447 (599)	485 (650)	542 (727)	2800	280 (617)
MG-5135 RV	PX-11945	—	1.16, 1.25, 1.53, 1.79, 2.00, 2.52	447 (599)	485 (650)	542 (727)	2800	258 (568)
MGX-5145 SC	PX-12460	1, 0	1.03, 1.20, 1.33, 1.48, 1.75, 1.96 2.50	553 (742) 473 (634)	596 (800) 522 (700)	637 (854) 597 (801)	2500	325 (716)
MGX-5145 A	PX-12420	1, 0	1.26, 1.48, 1.75, 1.96 2.50	553 (742) 473 (634)	596 (800) 522 (700)	637 (854) 597 (801)	2500	333 (734)
MGX-5145 RV	PX-12530	—	1.26, 1.48, 1.75, 1.96 2.50	553 (742) 473 (634)	596 (800) 522 (700)	637 (854) 597 (801)	2500	295 (650)
MG-5145 SC	PX-10885	1, 0	1.03, 1.20, 1.33, 1.48, 1.75, 1.96 2.50	553 (742) 473 (634)	596 (800) 522 (700)	637 (854) 597 (801)	2500	325 (716)
MG-5145 A	PX-10830	1, 0	1.26, 1.48, 1.75, 1.96 2.50	553 (742) 473 (634)	596 (800) 522 (700)	637 (854) 597 (801)	2500	333 (734)
MG-5145 RV	PX-10880	—	1.26, 1.48, 1.75, 1.96 2.50	553 (742) 473 (634)	596 (800) 522 (700)	637 (854) 597 (801)	2500	295 (650)
MGX-5147 SC	PX-12470-A	1, 0	1.20, 1.33, 1.48, 1.57, 1.75, 1.96 2.50	623 (835) 500 (671)	671 (900) 552 (740)	714 (957) 631 (846)	2500	325 (716)
MGX-5147 A	PX-12430-A	1, 0	1.26, 1.48, 1.75, 1.96 2.50	623 (835) 500 (671)	671 (900) 552 (740)	714 (957) 631 (846)	2500	333 (734)
MGX-5147 RV	PX-12540-A	—	1.03, 1.20, 1.33, 1.48, 1.75, 1.96 2.50	623 (835) 500 (671)	671 (900) 552 (740)	714 (957) 631 (846)	2500	295 (650)
MGX-516 DC	1023380	1, 0 (14" only)	3.07, 3.50, 4.04, 4.52, 5.05 6.00	397 (532) 365 (489)	447 (600) 406 (544)	465 (624) 425 (570)	2500	717 (1580)
MGX-5170 DC	1023382	1, 0	3.12, 3.54, 4.06, 4.50, 5.03, 5.95 6.53, 6.95	475 (637) 415 (557)	537 (720) 499 (615)	578 (775) 469 (669)	2500	850 (1872)
MG-520-1HP	XA-7255-B	0	4.49, 5.00, 6.11 7.00 7.42	609 (817) 580 (778) 542 (727)	685 (919) 645 (865) 603 (809)	799 (1071) 739 (991) 691 (927)	2500	1559 (3436)
MG-5202 SC	1016103-C	1, 0 Ind.	1.17, 1.33, 1.53, 1.76, 2.03 2.48, 2.92, 3.48	540 (724)	600 (805)	678 (909)	2500	587 (1292)
MG-5203 SC	1016249-A	1, 0 Ind.	1.17, 1.33, 1.53, 1.76, 2.03 2.48, 2.92, 3.48	540 (724)	600 (805)	678 (909)	2500	409 (900)
MG-5204 SC	1016250-B	1, 0 Ind.	1.17, 1.33, 1.53, 1.76, 2.03, 2.48, 2.92 3.48	633 (849) 540 (724)	716 (960) 600 (805)	797 (1069) 678 (909)	2750 (2500 at 1.17:1)	409 (900)
MGX-5222 DC	1022822-A	1, 0 Ind.	4.03, 4.59, 5.04, 6.10, 6.55, 6.96	540 (724)	600 (805)	678 (909)	2500	1046 (2304)
MGX-5225 DC	1022825-A	1, 0 Ind.	4.03, 4.59, 5.04, 5.57, 6.10	644 (864)	727 (975)	787 (1055)	2500	1046 (2304)
MGX-5321 DC	1022203-B	0, 00 Ind.	3.35, 4.06, 4.42, 4.96, 5.46 5.96 6.39	928 (1244) 865 (1160) 776 (1041)	1044 (1400) 956 (1282) 863 (1157)	1069 (1434) 1035 (1388) 967 (1297)	2400	1754 (3864)
MG-540 (with rubber block drive)	X-9882-C	0 00, Ind.	1.93, 2.58, 2.90 3.26 3.91 4.10, 4.60 5.17 6.18 7.00 7.47	746 (1000) 666 (893) 597 (800) 732 (982) 662 (888) 636 (853) 519 (696) 492 (660)	924 (1239) 855 (1147) 776 (1041) 917 (1230) 847 (1136) 820 (1100) 681 (913) 651 (873)	999 (1340)* 950 (1274)* 866 (1161)* 990 (1328)* 941 (1262)* 913 (1224)* 762 (1022)* 740 (992)*	1900* 2100* 2400* 1900* 2100* 2400* 2400* 2400*	2019 (4450) 2105 (4640)

Important - See rating definitions, application information, and torsional compatibility notices on pages 1 and 2.
Ratings shown are in SAE Horsepower (HP). Metric Horsepower equals SAE times 1.014.
Weights are approximate and include flywheel housing adapter and flexible input coupling.

* The max. input speed is 1650 rpm if MG-540 - SAE #00 is used with 21" rubber block drive.

MEDIUM DUTY RATINGS FOR STANDARD & QUICKSHIFT® MARINE TRANSMISSIONS (Continued)



Model	Drawing Number	SAE Housing	Ratios	KILOWATTS (HORSEPOWER)			Maximum Speed (rpm)	Dry Weight (kg)
				@ 1200 RPM	@ 1600 RPM	@ 1800 RPM		
MG-540 (with flexible coupling)	X-9882-C	0 00, Ind.	1.93, 2.58, 2.90	787 (1055)	1049 (1407)	1180 (1582)	1900	2019 (4450) 2105 (4640)
			3.26	869 (1165)	1034 (1387)	1163 (1560)	2100	
			3.91	648 (869)	864 (1159)	972 (1303)	2400	
			4.10, 4.60	787 (1055)	1049 (1407)	1180 (1582)	1900	
			5.17	774 (1038)	1032 (1384)	1161 (1557)	2100	
			6.18	644 (864)	859 (1152)	966 (1295)	2400	
			7.00	571 (766)	762 (1022)	857 (1149)	2400	
			7.47	535 (717)	715 (959)	804 (1078)	2400	
MG-5506	000005604	0, 00 Ind.	4.03, 4.55, 4.96, 5.44	960 (1287)	1281 (1718)	1441 (1932)	2000	2200 (4846)
			6.00	869 (1165)	1159 (1554)	1304 (1749)		
MGX-5600	1022780	0, 00 Ind.	2.53, 2.98, 3.51, 4.03, 4.63, 5.04	1230 (1649)	1598 (2143)	1760 (2360)	2100	3132 (6890)
			5.76	1200 (1609)	1566 (2100)	1737 (2329)		
			6.04	1016 (1362)	1309 (1755)	1451 (1946)		
				@ 1600 RPM	@ 1800 RPM	@ 2100 RPM		
MG-6449 A	7-37423	1, 0 Ind.	1.51, 1.73	680 (912)	741 (994)	833 (1117)	2500	344 (757)
			2.07	565 (758)	617 (827)	695 (932)		
			2.44	494 (662)	537 (720)	602 (807)		
			2.95	435 (583)	489 (656)	570 (764)		
MG-6449 RV	7-37431-A	—	1.51, 1.73	680 (912)	741 (994)	833 (1117)	2500	325 (716)
			2.07	565 (758)	617 (827)	695 (932)		
			2.44	494 (662)	537 (720)	602 (807)		
			2.95	435 (583)	489 (656)	570 (764)		
MGX-6598 DC	7-40379	1, 0 Ind.	2.46, 3.03	759 (1018)	824 (1105)	918 (1231)	2500	580 (1278)
			3.48	717 (961)	779 (1045)	868 (1164)		
			3.93	653 (876)	710 (952)	790 (1059)		
			4.43	609 (817)	662 (888)	737 (988)		
MGX-6599 SC	7-40384	1, 0 Ind.	1.07, 1.30, 1.50, 1.66, 1.74, 1.97, 2.04	713 (956)	774 (1038)	862 (1156)	2500	492 (1084)
			2.19, 2.45	713 (956)	774 (1038)	862 (1156)		
			2.82	615 (825)	668 (896)	744 (998)		
MGX-6599 A	7-40263	1, 0 Ind.	1.34, 1.51, 1.74, 2.03, 2.24	754 (1011)	820 (1100)	910 (1220)	2500	488 (1075)
			2.48	711 (953)	772 (1035)	860 (1153)		
			2.80	654 (877)	709 (951)	790 (1059)		
MGX-6599 RV	7-40336	—	1.34, 1.51, 1.74, 2.03, 2.24	754 (1011)	820 (1100)	910 (1220)	2500	468 (1031)
			2.48	711 (953)	772 (1035)	860 (1153)		
			2.80	654 (877)	709 (951)	790 (1059)		
MG-6600 DC	7-36712-A	0 Ind.	3.30, 4.11	884 (1185)	960 (1287)	998 (1338)	2500	575 (1267)
			4.68, 4.72	861 (1155)	935 (1254)	998 (1338)		
			5.22	834 (1118)	906 (1215)	998 (1338)		
			6.05	773 (1037)	839 (1125)	935 (1254)		
MGX-6620 SC	7-40337	0 Ind.	1.15, 1.33, 1.53, 1.73	884 (1185)	960 (1287)	998 (1338)	2500	794 (1747)
			2.03, 2.32	861 (1155)	935 (1254)	998 (1338)		
			2.44	834 (1118)	906 (1215)	998 (1338)		
			2.72	773 (1037)	839 (1125)	935 (1254)		
MGX-6620 A	7-40264	0 Ind.	1.55, 1.72, 2.09	926 (1242)	1021 (1369)	1132 (1518)	2500	580 (1278)
			2.28, 2.42	868 (1164)	943 (1265)	1050 (1408)		
			2.73	769 (1031)	835 (1120)	930 (1247)		
MGX-6620 RV	7-40316	—	1.55, 1.72, 2.09	926 (1242)	1021 (1369)	1132 (1518)	2500	510 (1123)
			2.28, 2.42	868 (1164)	943 (1265)	1050 (1408)		
			2.73	769 (1031)	835 (1120)	930 (1247)		

Important - See rating definitions, application information, and torsional compatibility notices on pages 1 and 2.
Ratings shown are in SAE Horsepower (HP). Metric Horsepower equals SAE times 1.014.
Weights are approximate and include flywheel housing adapter and flexible input coupling.

MEDIUM DUTY RATINGS FOR STANDARD & QUICKSHIFT® MARINE TRANSMISSIONS (Continued)



Model	Drawing Number	SAE Housing	Ratios	KILOWATTS (HORSEPOWER)			Maximum Speed (rpm)	Dry Weight (kg (lb))
				@ 1600 RPM	@ 1800 RPM	@ 2100 RPM		
MGX-6650 SC	1002046	0, 00 Ind.	1.51, 1.88, 2.03, 2.37 2.47, 2.93, 3.21	928 (1244)	1044 (1400)	1174 (1574)	2300 (1.51-2.37) 2500 (2.47-3.21)	1001 (2205)
MGX-6690 SC	1020674	0, 00 Ind.	1.51, 1.88, 2.03, 2.37, 2.47 2.93 3.21	1054 (1413) 1034 (1387) 1018 (1365)	1174 (1574) 1144 (1534) 1119 (1501)	1277 (1712) 1209 (1621) 1194 (1601)	2300 (1.51-2.37) 2500 (2.47-3.21)	1001 (2205)
MGX-6848 SC	1020675	0, 00 Ind.	1.51, 1.88, 2.03, 2.47 2.58, 2.93 3.21	1187 (1592) 1187 (1592) 1103 (1479)	1342 (1800) 1342 (1800) 1226 (1644)	1566 (2100) 1518 (2036) 1404 (1883)	2300 (1.51-2.03) 2500 (2.47-3.21)	1001 (2205)
				@ 1200 RPM	@ 1600 RPM	@ 1800 RPM		
MG-6984 SC	7-37008 7-37481 P-71034-B	Ind. 0 00	1.18, 1.54, 2.06, 2.29, 2.52, 2.92 3.25 3.43	902 (1210) 818 (1097) 616 (826)	1203 (1613) 1090 (1462) 821 (1101)	1353 (1814) 1227 (1645) 924 (1239)	2100	1192 (2628)
MG-6984 A	7-37028 P-71093 P-71094	Ind. 0 00	1.48, 1.97, 2.50, 2.79 2.93	923 (1238) 887 (1189)	1230 (1649) 1182 (1585)	1384 (1856) 1330 (1784)	2100	909 (2000)
MG-6984 RV	7-37042	—	1.48, 1.97, 2.50, 2.79 2.93	923 (1238) 887 (1189)	1230 (1649) 1182 (1585)	1384 (1856) 1330 (1784)	2100	909 (2000)
MGX-61000 SC *	1024420	00 Ind.	2.22, 2.54, 2.72, 3.03, 3.39	1119 (1500)	1491 (2000)	1678 (2250)	2100	1780 (3920)
MG-61242 SC	7-37017	Ind.	1.16, 1.52, 2.08, 2.47 2.96	1315 (1763) 1268 (1700)	1754 (2352) 1691 (2268)	1973 (2646) 1902 (2551)	2100	1050 (2310)
MG-61242 A	7-37046	Ind.	1.42, 2.07, 2.44 2.93	1315 (1763) 1263 (1694)	1754 (2352) 1685 (2260)	1973 (2646) 1896 (2543)	2100	1105 (2431)
MG-61242 RV	7-37049	—	1.42, 2.07, 2.44 2.93	1315 (1763) 1263 (1694)	1754 (2352) 1685 (2260)	1973 (2646) 1896 (2543)	2100	1105 (2431)
MGX-61500 SC *	1024500	Ind.	1.84, 1.98, 2.45, 2.97 3.03, 3.41	1560 (2092) 1333 (1788)	2080 (2789) 1778 (2384)	2340 (3138) 2000 (2682)	2100	1920 (4230)
MGX-61500 SC-HL** MGX-61500 SC-HR**	1023610 1023611	Ind.	1.84, 1.98, 2.18, 2.45, 2.97	1560 (2092)	2080 (2789)	2340 (3138)	2100	2200 (4846)

* Consult Twin Disc for availability of MGX-61000 SC and MGX-61500 SC, all ratios.

** Consult Twin Disc for availability and technical details to the horizontal offset transmissions MGX-61500 SC-HL and MGX-61500 SC-HR.

CONTINUOUS DUTY RATINGS FOR STANDARD & QUICKSHIFT® MARINE TRANSMISSIONS



Model	Drawing Number	SAE Housing	Ratios	KILOWATTS (HORSEPOWER)			Maximum Speed (rpm)	Dry Weight (kg (lb))
				@ 1800 RPM	@ 2100 RPM	@ 2300 RPM		
MG-340	IT101317501	5, BW	1.45 2.00 2.60	18 (24) 13 (17) 9 (12)	21 (28) 15 (20) 11 (15)	23 (31) 16 (21) 12 (16)	4500	9 (20)
MG-360	IT101318505	5, BW	1.55 2.00 2.45 2.83	23 (31) 21 (28) 17 (23) 14 (19)	26 (35) 24 (32) 20 (27) 16 (22)	29 (39) 26 (35) 21 (28) 17 (23)	5000	14 (31)
MG-5005 A	IT345ATD0001	3, 4, 5	1.54, 2.00 2.47	35 (47) 26 (35)	41 (55) 30 (40)	45 (60) 33 (44)	4500	25 (55)
MG-5012 SC	IT1013079801	3, 4, BW	1.52 2.09 2.40 2.78	74 (99) 64 (86) 58 (77) 50 (67)	86 (115) 75 (100) 67 (90) 58 (78)	94 (126) 82 (110) 74 (99) 64 (86)	4500	53 (117)
MG-5020 SC	IT1013049801	3, 4, BW	1.50, 2.04 2.50 2.94	104 (139) 83 (111) 72 (96)	121 (162) 97 (130) 84 (112)	133 (178) 106 (142) 92 (123)	4000	75 (165)
MG-5025 A	IT1013170	3, 4, BW	1.52, 2.09 2.40	59 (79) 52 (70)	69 (93) 61 (82)	75 (101) 67 (90)	4500	36 (79)
MG-5055 A	IT101316101	3, 4, BW	1.53, 2.08 2.60	105 (141) 60 (82)	123 (165) 70 (95)	135 (181) 77 (103)	4000	54 (119)
MG-5010 DC	PX-9400	3, 4, BW	3.00 3.52 4.00	70 (94) 61 (82) 55 (74)	82 (110) 72 (96) 65 (87)	93 (125) 82 (110) 74 (100)	4000	75 (165)
MG-5011 SC	PX-10270	3, 4, BW	1.11, 1.27, 1.50, 2.00 2.44	67 (90) 52 (70)	75 (101) 60 (80)	82 (110) 67 (90)	4400	49 (109)
MG-5011 A	PX-9999	3, 4, BW	1.44, 1.90 2.39	67 (90) 60 (80)	75 (101) 67 (90)	82 (110) 75 (101)	4400	49 (109)
MG-5011 IV	PX-10290	3, 4, BW	1.14, 1.54, 2.06 2.51	67 (90) 52 (70)	75 (101) 60 (80)	82 (110) 67 (90)	4400	77 (170)
MG-5050 SC	PX-12700	1, 2, 3, 4 SPEC. #3	1.00, 1.23, 1.53, 1.71, 2.04, 2.45 3.00	104 (139) 93 (125)	116 (156) 108 (145)	127 (170) 121 (162)	3300	86 (189)
MG-5050 A	PX-12730	1, 2, 3, 4 SPEC. #3	1.12, 1.26, 1.50, 1.80, 2.04, 2.50	104 (139)	116 (156)	127 (170)	3300	80 (176)
MG-5050 RV	PX-8760	—	1.12, 1.26, 1.50, 1.80, 2.04, 2.50	104 (139)	116 (156)	127 (170)	3300	73 (160)
MG-506-1	XA-7022-A XA-7048-A	1, 2, 3 1, 2, 3	1.09, 1.50, 1.97 2.50, 2.96	94 (126) 94 (126)	104 (140) 104 (140)	110 (147) 110 (147)	3000 3000	100 (220) 102 (224)
MG-5061 SC	PX-11650/-A	1, 2, 3 SPEC. #3	1.15, 1.48, 1.77, 2.00, 2.43 3.00	123 (165) 115 (154)	142 (190) 133 (178)	155 (208) 145 (194)	3300	98 (215)
MG-5061 A	PX-11640/-A	1, 2, 3 SPEC. #3	1.13, 1.28, 1.54, 1.75, 2.00 2.47	123 (165) 115 (154)	142 (190) 133 (178)	155 (208) 145 (194)	3300	95 (210)
MG-5061 V	PX-8735	—	1.13, 1.28, 1.54, 1.75, 2.00 2.47	123 (165) 115 (154)	142 (190) 133 (178)	155 (208) 145 (194)	3300	95 (210)
MG-5062 V	PX-11660/-A	1, 2, 3 SPEC. #3	1.19, 1.53, 1.83, 2.07, 2.51	123 (165)	142 (190)	155 (208)	3300	142 (312)
MGX-5065 SC	PX-12410	1, 2, 3 SPEC. #3	1.08, 1.26, 1.47, 1.72, 2.04 2.43	216 (290) 199 (267)	250 (335) 232 (311)	272 (365) 254 (341)	3300	111 (244)
MGX-5065 A	PX-12370	1, 2, 3 SPEC. #3	1.08, 1.26, 1.47, 1.72, 2.04 2.43	216 (290) 199 (267)	250 (335) 232 (311)	272 (365) 254 (341)	3300	111 (244)
MG-5065 SC	PX-11480	1, 2, 3 SPEC. #3	1.08, 1.26, 1.47, 1.72, 2.04 2.43	216 (290) 199 (267)	250 (335) 232 (311)	272 (365) 254 (341)	3300	111 (244)
MG-5065 A	PX-11165	1, 2, 3 SPEC. #3	1.08, 1.26, 1.47, 1.72, 2.04 2.43	216 (290) 199 (267)	250 (335) 232 (311)	272 (365) 254 (341)	3300	111 (244)

Important - See rating definitions, application information, and torsional compatibility notices on pages 1 and 2.
Ratings shown are in SAE Horsepower (HP). Metric Horsepower equals SAE times 1.014.
Weights are approximate and include flywheel housing adapter and flexible input coupling.

CONTINUOUS DUTY RATINGS FOR STANDARD & QUICKSHIFT® MARINE TRANSMISSIONS (Continued)



Model	Drawing Number	SAE Housing	Ratios	KILOWATTS (HORSEPOWER)			Maximum Speed (rpm)	Dry Weight (kg (lb))
				@ 1800 RPM	@ 2100 RPM	@ 2300 RPM		
MGX-5075 SC	PX-12620	1, 2, 3 SPEC. #3	1.06, 1.22, 1.33, 1.53, 1.77, 2.05 2.53, 2.88	186 (249)	209 (280)	224 (300)	3500	122 (268)
MGX-5075 A	PX-12610	1, 2, 3 SPEC. #3	1.06, 1.22, 1.33, 1.53, 1.77, 2.05 2.53, 2.88	186 (249)	209 (280)	224 (300)	3500	122 (268)
MGX-5075 IV	PX-12630	1, 2, 3 SPEC. #3	1.03, 1.30, 1.49, 1.72, 1.99, 2.46	186 (249)	209 (280)	224 (300)	3500	150 (330)
MG-5075 SC	PX-10680/A	1, 2, 3 SPEC. #3	1.06, 1.22, 1.33, 1.53, 1.77, 2.05 2.53, 2.88	186 (249)	209 (280)	224 (300)	3500	122 (268)
MG-5075 A	PX-10700/A	1, 2, 3 SPEC. #3	1.06, 1.22, 1.33, 1.53, 1.77, 2.05 2.53, 2.88	186 (249)	209 (280)	224 (300)	3500	122 (268)
MG-5075 IV	PX-11530	1, 2, 3 SPEC. #3	1.03, 1.30, 1.49, 1.72, 1.99, 2.46	186 (249)	209 (280)	224 (300)	3500	150 (330)
MG-509	X-9816-F	1, 2	1.45, 2.00 2.48 2.95 3.39	175 (235) 170 (228) 170 (228) 128 (170)	204 (273) 194 (260) 186 (250) 148 (198)	224 (300)* 213 (285)* 205 (275)* 160 (215)*	3000*	259 (572)
	X-9835	1, 2	3.83, 4.50 4.95	175 (235) 134 (180)	204 (273) 157 (210)	224 (300)* 172 (230)*	3000*	323 (712)
MG-5085 SC	PX-9260-B/-C	1, 2, 3 SPEC. #3	1.05, 1.22, 1.42, 1.76, 1.96 2.33	227 (304) 205 (275)	254 (340) 231 (310)	265 (355) 243 (326)	3200	120 (265)
MG-5085 A	PX-9360-B/-C	1, 2, 3 SPEC. #3	1.05, 1.22, 1.47, 1.72, 2.04 2.43	227 (304) 205 (275)	254 (340) 231 (310)	265 (355) 243 (326)	3200	123 (270)
MG-5082 SC	PX-11250-A	1, 2	1.06, 1.33, 1.53, 1.77, 2.05, 2.53 2.88	262 (351)	292 (392)	310 (416)	3200	135 (298)
MG-5082 A	PX-11040-B	1, 2	1.06, 1.33, 1.53, 1.77, 2.05, 2.53 2.88	262 (351)	292 (392)	310 (416)	3200	135 (298)
MGX-5086 SC	PX-12600	1, 2	1.06, 1.33, 1.53, 1.77, 2.05, 2.53 2.88	262 (351)	292 (392)	310 (416)	3200	135 (298)
MGX-5086 A	PX-12290	1, 2	1.06, 1.33, 1.53, 1.77, 2.05, 2.53 2.88	262 (351)	292 (392)	310 (416)	3200	135 (298)
MG-5091 SC	PX-10016	1, 2	1.17, 1.45, 1.71, 2.04, 2.45, 2.95 3.33	242 (325) 205 (275)	280 (375) 239 (320)	306 (410) 261 (350)	3000	220 (485)
MG-5091 DC	1002155	1, 2	3.82, 4.50 5.05	242 (325) 205 (275)	280 (375) 239 (320)	306 (410) 261 (350)	3000	297 (655)
MG-5090 A	PX-10015	1, 2	1.45, 1.73, 1.96, 2.43	239 (320)	276 (370)	287 (385)	3000	216 (475)
MGX-5095 SC	PX-12480	1, 2	1.15, 1.27, 1.47, 1.71, 2.00, 2.46 2.95	298 (400)	335 (449)	360 (483)	3000	190 (419)
MGX-5095 A	PX-12360	1, 2	1.28, 1.52, 1.81, 2.04 2.48	298 (400)	335 (449)	360 (483)	3000	185 (407)
MGX-5095 RV	PX-12550	—	1.28, 1.52, 1.81, 2.04 2.48	298 (400)	335 (449)	360 (483)	3000	178 (392)
MG-5095 SC	PX-11535	1, 2	1.15, 1.27, 1.47, 1.71, 2.00, 2.46 2.95	298 (400)	335 (449)	360 (483)	3000	190 (419)
MG-5095 A	PX-11495	1, 2	1.28, 1.52, 1.81, 2.04 2.48	298 (400)	335 (449)	360 (483)	3000	185 (407)
MG-5095 RV	PX-11600	—	1.28, 1.52, 1.81, 2.04 2.48	298 (400)	335 (449)	360 (483)	3000	178 (392)

Important – See rating definitions, application information, and torsional compatibility notices on pages 1 and 2.
Ratings shown are in SAE Horsepower (HP). Metric Horsepower equals SAE times 1.014.
Weights are approximate and include flywheel housing adapter and flexible input coupling.

* A6911 diving ring has 2150 rpm maximum speed.

CONTINUOUS DUTY RATINGS FOR STANDARD & QUICKSHIFT® MARINE TRANSMISSIONS (Continued)



Model	Drawing Number	SAE Housing	Ratios	KILOWATTS (HORSEPOWER)			Maximum Speed (rpm)	Dry Weight (kg (lb))
				@ 1800 RPM	@ 2100 RPM	@ 2300 RPM		
MGX-5114 SC	PX-12490	1	0.93, 1.02, 1.12, 1.50, 1.74 2.04, 2.54 3.00	358 (480) 358 (480) 328 (440)	410 (550) 410 (550) 373 (500)	444 (595) 444 (595) 403 (540)	2800 at .93:1 3000 for others	203 (447)
MGX-5114 SC-HD	PX-12860	1	1.50, 1.74, 2.04, 2.54 3.00	358 (480) 328 (440)	410 (550) 373 (500)	444 (595) 403 (540)	3000	270 (595)
MGX-5114 DC	PX-12170	1	3.28, 3.43, 4.17, 4.59, 4.86	347 (465)	403 (540)	421 (565)	3000	360 (793)
MGX-5114 A	1024390	1, 2	1.03, 1.20, 1.48, 1.75, 1.92, 2.04 2.50	347 (465) 321 (430)	387 (519) 366 (491)	418 (561) 396 (531)	3000	206 (455)
MGX-5114 RV	PX-11850	—	1.03, 1.20, 1.48, 1.75, 1.92, 2.04 2.50	347 (465) 321 (430)	387 (519) 366 (491)	418 (561) 396 (531)	3000	198 (435)
MGX-5114 IV	PX-12510	1, 2	1.05, 1.23, 1.52, 1.80, 1.97 2.57	347 (465) 321 (430)	387 (519) 366 (491)	418 (561) 396 (531)	3000	270 (595)
MG-5114 SC	PX-9785-B	1	0.93, 1.02, 1.12, 1.50, 1.74, 2.04, 2.54 3.00	358 (480) 328 (440)	410 (550) 373 (500)	444 (595) 403 (540)	2800 at .93:1 3000 for others	203 (447)
MG-5114 SC-HD	PX-11962	1 Ind.	1.50, 1.74, 2.04, 2.54 3.00	358 (480) 328 (440)	410 (550) 373 (500)	444 (595) 403 (540)	3000	270 (595)
MG-5114 DC	PX-10250-A PX-12195(FS)	1 Ind.	3.28, 3.43, 4.17, 4.59, 4.86	347 (465)	403 (540)	421 (565)	3000	368 (810)
MG-5114 A	PX-11915	1, 2	1.03, 1.20, 1.48, 1.75, 1.92, 2.04 2.50	347 (465) 321 (430)	387 (519) 366 (491)	418 (561) 396 (531)	3000	206 (455)
MG-5114 RV	PX-9830-A	—	1.03, 1.20, 1.48, 1.75, 1.92, 2.04 2.50	347 (465) 321 (430)	387 (519) 366 (491)	418 (561) 396 (531)	3000	198 (435)
MG-5114 IV	PX-11920	1, 2	1.05, 1.23, 1.52, 1.80, 1.97 2.57	347 (465) 321 (430)	387 (519) 366 (491)	418 (561) 396 (531)	3000	270 (595)
				@ 1600 RPM	@ 1800 RPM	@ 2100 RPM		
MG-514C SC	X-9784-C	1, 0 (14" only)	1.51, 2.00, 2.50, 3.00, 3.50	254 (340)	283 (380)	313 (420)	2500	524 (1155)
MG-514C DC	X-9786-C	1, 0 (14" only)	4.13, 4.50, 5.16 6.00	254 (340) 242 (325)	283 (380) 272 (365)	313 (420) 302 (405)	2500	658 (1450)
MGX-5135 SC	PX-12450	1, 0	1.10, 1.28, 1.48, 1.73, 2.04, 2.57 2.90	410 (550) 376 (504)	445 (597) 408 (547)	497 (666) 456 (611)	2800	300 (661)
MGX-5135 A	PX-12380	1, 0	1.16, 1.25, 1.53, 1.79, 2.00 2.52	410 (550)	445 (597)	497 (666)	2800	280 (617)
MGX-5135 RV	PX-12520	—	1.16, 1.25, 1.53, 1.79, 2.00 2.52	410 (550)	445 (597)	497 (666)	2800	258 (568)
MG-5135 SC	PX-11590	1, 0	1.10, 1.28, 1.48, 1.73, 2.04, 2.57 2.90	410 (550) 376 (504)	445 (597) 408 (547)	497 (666) 456 (611)	2800	300 (661)
MG-5135 A	PX-11380	1, 0	1.16, 1.25, 1.53, 1.79, 2.00 2.52	410 (550)	445 (597)	497 (666)	2800	280 (617)
MG-5135 RV	PX-11945	—	1.16, 1.25, 1.53, 1.79, 2.00 2.52	410 (550)	445 (597)	497 (666)	2800	258 (568)
MGX-5145 SC	PX-12460	1, 0	1.03, 1.20, 1.33, 1.48, 1.75, 1.96 2.50	510 (684) 438 (587)	552 (740) 485 (650)	596 (799) 555 (744)	2500	325 (716)
MGX-5145 A	PX-12420	1, 0	1.26, 1.48, 1.75, 1.96 2.50	510 (684) 438 (587)	552 (740) 485 (650)	596 (799) 555 (744)	2500	333 (734)
MGX-5145 RV	PX-12530	—	1.26, 1.48, 1.75, 1.96 2.50	510 (684) 438 (587)	552 (740) 485 (650)	596 (799) 555 (744)	2500	295 (650)
MG-5145 SC	PX-10885	1, 0	1.03, 1.20, 1.33, 1.48, 1.75, 1.96 2.50	510 (684) 438 (587)	552 (740) 485 (650)	596 (799) 555 (744)	2500	325 (716)
MG-5145 A	PX-10830	1, 0	1.26, 1.48, 1.75, 1.96 2.50	510 (684) 438 (587)	552 (740) 485 (650)	596 (799) 555 (744)	2500	333 (734)
MG-5145 RV	PX-10880	—	1.26, 1.48, 1.75, 1.96 2.50	510 (684) 438 (587)	552 (740) 485 (650)	596 (799) 555 (744)	2500	295 (650)

Important – See rating definitions, application information, and torsional compatibility notices on pages 1 and 2.
Ratings shown are in SAE Horsepower (HP). Metric Horsepower equals SAE times 1.014.
Weights are approximate and include flywheel housing adapter and flexible input coupling.

CONTINUOUS DUTY RATINGS FOR STANDARD & QUICKSHIFT® MARINE TRANSMISSIONS (Continued)



Model	Drawing Number	SAE Housing	Ratios	KILOWATTS (HORSEPOWER)			Maximum Speed (rpm)	Dry Weight (kg (lb))
				@ 1600 RPM	@ 1800 RPM	@ 2100 RPM		
MGX-5147 SC	PX-12470-A	1, 0	1.20, 1.33, 1.48, 1.57, 1.75, 1.96 2.50	565 (758) 481 (645)	612 (821) 537 (720)	660 (885) 615 (825)	2500	325 (716)
MGX-5147 A	PX-12430-A	1, 0	1.26, 1.48, 1.75, 1.96 2.50	565 (758) 481 (645)	612 (821) 537 (720)	660 (885) 615 (825)	2500	333 (734)
MGX-5147 RV	PX-12540-A	—	1.03, 1.20, 1.33, 1.48, 1.75, 1.96 2.50	565 (758) 481 (645)	612 (821) 537 (720)	660 (885) 615 (825)	2500	295 (650)
MGX-516 DC	1023380	1, 0 (14" only)	3.07, 3.50, 4.04, 4.52, 5.05 6.00	397 (532) 365 (489)	447 (600) 406 (544)	465 (624) 425 (570)	2500	717 (1580)
MGX-5170 DC	1023382	1, 0	3.12, 3.54, 4.06, 4.50, 5.03, 5.95 6.53, 6.95	448 (601) 408 (547)	507 (680) 459 (615)	541 (725) 478 (641)	2500	850 (1872)
MG-520-1HP	XA-7255-B	0	4.49, 5.00, 6.11 7.00 7.42	567 (760) 567 (760) 537 (720)	639 (857) 638 (856) 597 (801)	745 (999) 730 (979) 684 (917)	2500	1559 (3436)
MG-5202 SC	1016103-C	1, 0 Ind.	1.17, 1.33, 1.53, 1.76, 2.03, 2.48, 2.92 3.48	540 (724)	600 (805)	678 (909)	2500	587 (1292)
MG-5203 SC	1016249-A	1, 0 Ind.	1.17, 1.33, 1.53, 1.76, 2.03, 2.48, 2.92 3.48	540 (724)	600 (805)	678 (909)	2500	409 (900)
MG-5204 SC	1016250-B	1, 0 Ind.	1.17, 1.33, 1.53, 1.76, 2.03, 2.48, 2.92 3.48	633 (849) 540 (724)	716 (960) 600 (805)	797 (1069) 678 (909)	2750 (2500 at 1.17:1)	409 (900)
MGX-5222 DC	1022822-A	1, 0 Ind.	4.03, 4.59, 5.04, 6.10, 6.55, 6.96	540 (724)	600 (805)	678 (909)	2500	1046 (2304)
MGX-5225 DC	1022825-A	1, 0 Ind.	4.03, 4.59, 5.04, 5.57, 6.10	633 (849)	716 (960)	735 (986)	2500	1046 (2304)
MGX-5321 DC	1022203-B	0, 00 Ind.	3.35, 4.06, 4.42, 4.96, 5.46 5.96 6.39	882 (1183) 861 (1155) 737 (988)	982 (1317) 955 (1281) 812 (1089)	1000 (1341) 968 (1298) 905 (1214)	2400	1754 (3864)
				@ 1200 RPM	@ 1600 RPM	@ 1800 RPM		
MG-540 (with rubber block drive)	X-9882-C	0 00, Ind.	1.93, 2.58, 2.90 3.26 3.91 4.60 5.17 6.18 7.00 7.47	708 (949) 638 (856) 559 (750) 682 (915) 638 (856) 638 (856) 496 (665) 466 (625)	865 (1160) 809 (1085) 721 (967) 844 (1132) 809 (1085) 809 (1085) 663 (889) 647 (868)	943 (1265)* 895 (1200)* 802 (1075)* 925 (1240)* 895 (1200)* 895 (1200)* 746 (1000)* 738 (990)*	1900* 2100* 2400* 1900* 2100* 2400* 2400* 2400*	2019 (4450) 2105 (4640)
MG-540 (with flexible coupling)	X-9882-C	0 00, Ind.	1.93, 2.58, 2.90 3.26 3.91 4.60 5.17 6.18 7.00 7.47	787 (1055) 776 (1041) 648 (869) 787 (1055) 774 (1038) 644 (864) 571 (766) 535 (717)	1049 (1407) 1034 (1387) 864 (1159) 1049 (1407) 1032 (1384) 859 (1152) 762 (1022) 715 (959)	1180 (1582) 1163 (1560) 972 (1303) 1180 (1582) 1161 (1557) 966 (1295) 895 (1200) 804 (1078)	1900 2100 2400 1900 2100 2400 2400 2400	2019 (4450) 2105 (4640)
MG-5506	00D005604	0, 00 Ind.	4.03, 4.55, 4.96, 5.44 6.00	937 (1257) 848 (1137)	1249 (1675) 1130 (1515)	1406 (1885) 1279 (1715)	2000	2200 (4846)
MGX-5600	1022780	0, 00 Ind.	2.53, 2.98, 3.51, 4.03, 4.63, 5.04 5.76 6.04	1230 (1649) 1200 (1609) 985 (1321)	1575 (2112) 1566 (2100) 1271 (1704)	1760 (2360) 1737 (2329) 1410 (1891)	2100	3132 (6890)
MGX-5600DR	1022781	Ind.	4.20, 6.02 6.56 7.01 7.22	1151 (1543) 1038 (1392) 964 (1293) 845 (1133)	1564 (2097) 1458 (1955) 1352 (1813) 1088 (1459)	1760 (2360) 1641 (2201) 1566 (2100) 1207 (1619)	2100	3475 (7654)

Important – See rating definitions, application information, and torsional compatibility notices on pages 1 and 2.
Ratings shown are in SAE Horsepower (HP). Metric Horsepower equals SAE times 1.014.
Weights are approximate and include flywheel housing adapter and flexible input coupling.

* The max. input speed is 1650 rpm if MG-540 - SAE #00 is used with 21" rubber block drive.

CONTINUOUS DUTY RATINGS FOR STANDARD & QUICKSHIFT® MARINE TRANSMISSIONS (Continued)



Model	Drawing Number	SAE Housing	Ratios	KILOWATTS (HORSEPOWER)			Maximum Speed (rpm)	Dry Weight (kg (lb))
				@ 1200 RPM	@ 1600 RPM	@ 1800 RPM		
MGN-1814 V	PPD007097	Ind.	2.53, 3.00, 3.29 3.62, 4.00	1548 (2076)	2064 (2768)	2322 (3114)	1800	3000 (6608)
MGN-1816 V	PPD007098	Ind.	4.43, 4.85 5.33, 5.61	1548 (2076)	2064 (2768)	2322 (3114)	1800	3800 (8370)
MGN-1817 V	PPD007099	Ind.	6.66, 6.56, 6.88 7.22, 7.59	1548 (2076)	2064 (2768)	2322 (3114)	1800	4500 (9912)
MGN-1819 V	PLN005679	Ind.	8.88	1500 (2012)	2000 (2682)	2250 (3017)	1800	TBA (TBA)
				@ 1600 RPM	@ 1800 RPM	@ 2100 RPM		
MG-6449 A	7-37423	1, 0 Ind.	1.51, 1.73 2.07 2.44 2.95	640 (858) 529 (709) 462 (620) 413 (554)	695 (932) 574 (770) 502 (673) 448 (601)	778 (1043) 642 (861) 562 (754) 501 (672)	2500	344 (757)
MG-6449 RV	7-37431-A	—	1.51, 1.73 2.07 2.44 2.95	640 (858) 529 (709) 462 (620) 413 (554)	695 (932) 574 (770) 502 (673) 448 (601)	778 (1043) 642 (861) 562 (754) 501 (672)	2500	325 (716)
MGX-6598 DC	7-40379	1, 0 Ind.	2.46, 3.03 3.48 3.93 4.43	710 (952) 670 (898) 611 (819) 570 (764)	771 (1034) 729 (978) 664 (890) 619 (830)	858 (1151) 811 (1088) 739 (991) 690 (925)	2500	580 (1278)
MGX-6599 SC	7-40384	1, 0 Ind.	1.07, 1.30, 1.50, 1.66, 1.74 1.97, 2.04, 2.19, 2.45 2.82	685 (919) 670 (898) 575 (771)	744 (998) 728 (976) 624 (837)	828 (1110) 806 (1081) 696 (933)	2500	492 (1084)
MGX-6599 A	7-40263	1, 0 Ind.	1.34, 1.51, 1.74, 2.03, 2.24 2.48 2.80	706 (947) 668 (896) 644 (864)	767 (1029) 728 (976) 699 (937)	851 (1141) 804 (1078) 779 (1045)	2500	488 (1075)
MGX-6599 RV	7-40336	—	1.34, 1.51, 1.74, 2.03, 2.24 2.48 2.80	706 (947) 668 (896) 644 (864)	767 (1029) 728 (976) 699 (937)	851 (1141) 804 (1078) 779 (1045)	2500	468 (1031)
MG-6600 DC	7-36712-A	0 Ind.	3.30, 4.11 4.68, 4.72 5.22 6.05	637 (854) 623 (835) 534 (716) 473 (634)	716 (960) 701 (940) 600 (805) 532 (713)	835 (1120) 818 (1097) 699 (937) 621 (833)	2500	794 (1747)
MGX-6620 SC	7-40337	0 Ind.	1.15, 1.33, 1.53, 1.73 2.03 2.32 2.44 2.72	827 (1109) 810 (1086) 805 (1080) 780 (1046) 723 (970)	898 (1204) 879 (1179) 874 (1172) 847 (1136) 785 (1053)	934 (1252) 934 (1252) 934 (1252) 934 (1252) 875 (1173)	2500	575 (1267)
MGX-6620 A	7-40264	0 Ind.	1.55, 1.72, 2.09 2.28, 2.42 2.73	875 (1173) 767 (1029) 719 (964)	950 (1274) 833 (1117) 780 (1046)	1059 (1420) 928 (1244) 869 (1165)	2500	580 (1278)
MGX-6620 RV	7-40316	—	1.55, 1.72, 2.09 2.28, 2.42 2.73	875 (1173) 767 (1029) 719 (964)	950 (1274) 833 (1117) 780 (1046)	1059 (1420) 928 (1244) 869 (1165)	2500	510 (1123)
MGX-6650 SC	1002046	0, 00 Ind.	1.51, 1.88, 2.03, 2.37 2.47, 2.93, 3.21	911 (1222)	1025 (1375)	1098 (1472)	2300 (1.51–2.37) 2500 (2.47–3.21)	1001 (2205)
MGX-6690 SC	1020674	0, 00 Ind.	1.51, 1.88, 2.03, 2.37, 2.47 2.93 3.21	1017 (1364) 977 (1310) 943 (1265)	1129 (1514) 1069 (1434) 1028 (1379)	1195 (1602) 1130 (1515) 1098 (1472)	2300 (1.51–2.37) 2500 (2.47–3.21)	1001 (2205)
MGX-6848 SC	1020675	0, 00 Ind.	1.51, 1.88, 2.03, 2.47, 2.58, 2.93 3.21	1111 (1490) 1074 (1440)	1250 (1676) 1194 (1601)	1420 (1904) 1350 (1810)	2300 (1.51–2.03) 2500 (2.47–3.21)	1001 (2205)

Important – See rating definitions, application information, and torsional compatibility notices on pages 1 and 2.
Ratings shown are in SAE Horsepower (HP). Metric Horsepower equals SAE times 1.014.
Weights are approximate and include flywheel housing adapter and flexible input coupling.

**CONTINUOUS DUTY RATINGS FOR STANDARD &
QUICKSHIFT® MARINE TRANSMISSIONS (Continued)**



Model	Drawing Number	SAE Housing	Ratios	KILOWATTS (HORSEPOWER)			Maximum Speed (rpm)	Dry Weight (kg (lb))
				@ 1200 RPM	@ 1600 RPM	@ 1800 RPM		
MG-6984 SC	7-37008	Ind.	1.18, 1.54, 2.06, 2.29, 2.52, 2.92	884 (1185)	1178 (1580)	1326 (1778)	2100	1192 (2628)
	7-37481	0	3.25	800 (1073)	1066 (1430)	1200 (1609)		
	P-71034-B	00	3.43	602 (807)	802 (1075)	903 (1211)		
MG-6984 A	7-37028	Ind.	1.48, 1.97, 2.50, 2.79	905 (1214)	1206 (1617)	1356 (1818)	2100	909 (2000)
	P-71093	0	2.93	867 (1163)	1157 (1552)	1301 (1745)		
	P-71094	00						
MG-61242 SC	7-37017	Ind.	1.16, 1.52	1250 (1676)	1667 (2235)	1875 (2514)	2100	1050 (2310)
			2.08, 2.47, 2.96	1173 (1573)	1512 (2028)	1760 (2360)		
MG-61242 A	7-37046	Ind.	1.42, 2.07	1239 (1661)	1651 (2214)	1858 (2492)	2100	1105 (2431)
			2.44	1189 (1594)	1585 (2125)	1782 (2390)		
			2.93	1173 (1573)	1565 (2099)	1760 (2360)		

TWIN DISC MG-300, MG-500, MG-5000 and MGX-5000 SERIES CONFIGURATIONS

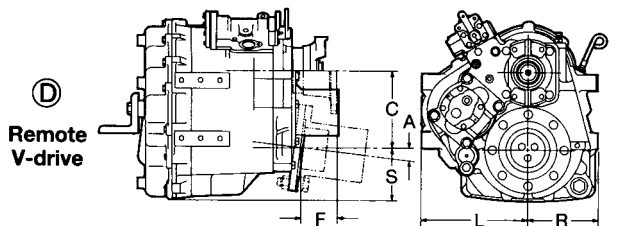
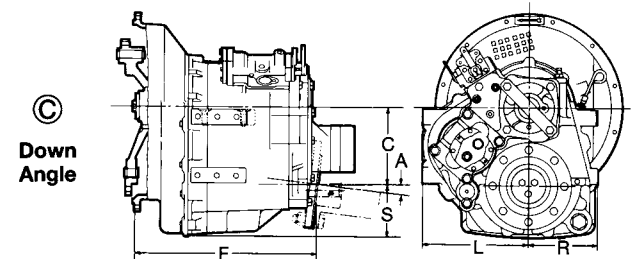
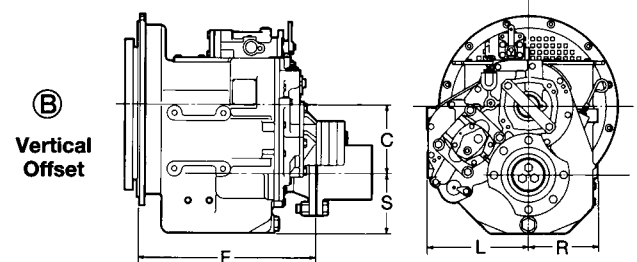
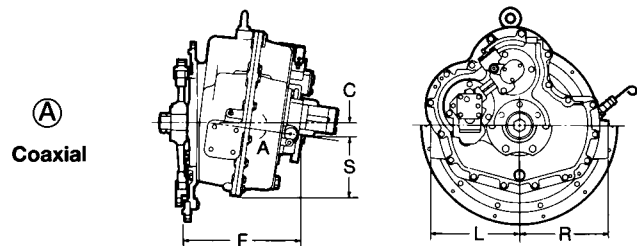

TWIN DISC MGX-5000 (QuickShift®) SERIES DIMENSIONAL DATA

Model	Assembly	Configuration	C (offset) in (mm)	S (sump) in (mm)	F (length) in (mm)	L (mounting pad) in (mm)	R (mounting pad) in (mm)	A degree	W (weight) lb (kg)
MGX-5065 SC	PX-12410	B	6.00 (152)	5.22 (133)	13.30 (338)	10.00 (254)	6.50 (165)	—	244 (111)
MGX-5065 A	PX-12370	C	6.69 (170)	4.84 (123)	12.97 (329)	10.00 (254)	6.50 (165)	7	244 (111)
MGX-5075 SC	PX-12620	A	0.59 (15)	7.00 (178)	14.11 (358)	10.00 (254)	10.00 (254)	—	268 (122)
MGX-5075 A	PX-12610	A	1.91 (48)	7.00 (178)	13.80 (350)	10.00 (254)	10.00 (254)	7	268 (122)
MGX-5075 IV	PX-12630	D*	14.70 (373)	3.93 (100)	2.34 (59)	10.00 (254)	10.00 (254)	15	330 (150)
MGX-5082 SC	PX-12600	A	0.59 (15)	7.00 (178)	16.24 (413)	10.00 (254)	10.00 (254)	—	298 (135)
MGX-5082 A	PX-12290	A	2.12 (54)	7.00 (178)	15.97 (405)	10.00 (254)	10.00 (254)	7	298 (135)
MGX-5095 SC	PX-12480	B	7.48 (190)	6.14 (156)	17.00 (432)	10.43 (265)	10.43 (265)	—	419 (190)
MGX-5095 A	PX-12360	C	7.43 (189)	5.54 (141)	17.00 (432)	10.43 (265)	10.43 (265)	7	407 (185)
MGX-5095 RV	PX-12550	D	7.43 (189)	5.54 (141)	2.37 (60)	10.43 (265)	10.43 (265)	7	392 (178)
MGX-5114 SC	PX-12490	B	7.47 (190)	6.33 (161)	19.00 (483)	11.00 (279)	7.50 (191)	—	447 (203)
MGX-5114 SC-HD	PX-12860	B	7.47 (190)	6.33 (161)	19.00 (483)	11.00 (279)	11.00 (279)	—	595 (270)
MGX-5114 DC	PX-12170	B	10.90 (277)	9.85 (250)	19.03 (483)	11.25 (286)	11.25 (286)	—	793 (360)
MGX-5114 A	1024390	C	8.00 (203)	5.30 (135)	18.80 (479)	11.00 (279)	8.00 (203)	7	455 (206)
MGX-5114 RV	PX-11850	D	8.00 (203)	5.25 (133)	2.51 (64)	11.00 (279)	8.00 (203)	7	435 (198)
MGX-5114 IV	PX-12510	D*	16.26 (413)	5.75 (146)	2.43 (62)	7.50 (191)	11.50 (292)	14	595 (270)
MGX-5135 SC	PX-12450	B	7.87 (200)	7.48 (190)	21.06 (535)	12.01 (305)	12.01 (305)	—	661 (300)
MGX-5135 A	PX-12380	C	9.09 (231)	6.28 (160)	20.48 (520)	12.01 (305)	12.01 (305)	10	617 (280)
MGX-5135 RV	PX-12520	D	9.09 (231)	6.28 (160)	3.70 (94)	12.01 (305)	12.01 (305)	10	568 (258)
MGX-5145 SC	PX-12460	B	8.12 (206)	7.04 (179)	21.05 (535)	12.01 (305)	12.01 (305)	—	716 (325)
MGX-5145 A	PX-12420	C	10.40 (264)	6.13 (156)	20.33 (516)	12.01 (305)	12.01 (305)	10	734 (333)
MGX-5145 RV	PX-12530	D	10.40 (264)	6.13 (156)	4.93 (125)	12.01 (305)	12.01 (305)	10	650 (295)
MGX-5147 SC	PX-12470-A	B	8.12 (206)	7.04 (179)	21.05 (535)	12.01 (305)	12.01 (305)	—	716 (325)
MGX-5147 A	PX-12430-A	C	10.40 (264)	6.13 (156)	20.33 (516)	12.01 (305)	12.01 (305)	10	734 (333)
MGX-5147 RV	PX-12540-A	D	10.40 (264)	6.13 (156)	4.93 (125)	12.01 (305)	12.01 (305)	10	650 (295)
MGX-516 DC	1023380	B	13.29 (338)	12.77 (324)	20.59 (523)	14.00 (356)	14.00 (356)	—	1580 (717)
MGX-5170 DC	1023382	B	15.15 (385)	14.23 (361)	22.55 (573)	15.00 (381)	15.00 (381)	—	1670 (759)
MGX-5222 DC	1022822	B	15.75 (400)	15.13 (384)	25.08 (637)	16.00 (406)	16.00 (406)	—	2304 (1046)
MGX-5225 DC	1022825	B	15.75 (400)	15.13 (384)	25.08 (637)	16.00 (406)	16.00 (406)	—	2304 (1046)
MGX-5321 DC	1022203-B	B	17.32 (440)	16.77 (426)	29.83 (758)	17.32 (440)	17.32 (440)	—	3864 (1754)
MGX-5600	1022780	B	21.65 (550)	21.26 (540)	41.02 (1042)	20.67 (525)	20.67 (525)	—	6890 (3132)
MGX-5600 DR	1022781	B	8.85 (225)	21.26 (540)	50.63 (1286)	20.67 (525)	20.67 (525)	—	7000 (3175)

TWIN DISC MG-300, MG-500, MG-5000 SERIES CONFIGURATIONS

Model	Assembly	Configuration	C (offset) in (mm)	S (sump) in (mm)	F (length) in (mm)	L (mounting pad) in (mm)	R (mounting pad) in (mm)	A degree	W (weight) lb (kg)
MG-340	IT40TD0002	B	2.66 (68)	2.46 (63)	7.17 (182)	—	2.95 (75)	—	20 (9)
MG-360	IT60TD0002	B	3.10 (79)	3.56 (83)	9.65 (245)	—	—	—	31 (14)
MG-5005 A	IT345ATD0001	C	4.37 (111)	3.19 (81)	8.82 (224)	—	—	8	55 (25)
MG-5012 SC	IT93TD0001	B	4.35 (110)	4.92 (125)	10.14 (258)	6.61 (168)	6.61 (168)	—	117 (53)
MG-5020 SC	IT170TD0001	B	5.18 (132)	5.17 (131)	10.53 (268)	7.60 (193)	7.60 (193)	—	165 (75)
MG-5025 A	IT485ATD0001	C	4.96 (126)	3.43 (87)	10.63 (270)	6.50 (165)	6.50 (165)	8	79 (36)
MG-5055 A	IT880ATD0002	C	6.10 (155)	4.25 (108)	10.51 (267)	7.60 (193)	7.60 (193)	10	119 (54)
MG-5010 DC	PX-9400	B	6.56 (167)	6.39 (162)	9.80 (249)	7.25 (184)	6.95 (177)	—	165 (75)
MG-5011 SC	PX-10270	B	4.10 (104)	3.50 (89)	8.59 (218)	6.75 (171)	5.00 (127)	—	109 (49)
MG-5011 A	PX-9999	C	4.65 (118)	3.66 (93)	7.62 (194)	6.75 (171)	5.00 (127)	10	104 (47)
MG-5011 IV	PX-10290	D*	10.09 (256)	6.75 (171)	5.00 (124)	6.75 (171)	5.00 (127)	15	170 (77)
MG-5050 SC	PX-12700	B	5.28 (134)	4.69 (119)	12.78 (325)	8.13 (207)	5.85 (149)	—	189 (86)
MG-5050 A	PX-12730	C	5.52 (140)	3.68 (93)	12.10 (307)	8.13 (207)	5.85 (149)	10	176 (80)
MG-5050 RV	PX-8760	D	5.52 (140)	3.68 (93)	4.61 (117)	8.13 (207)	5.85 (149)	10	160 (73)
MG-506-1	XA-7022-A	A	coax (0)	7.90 (201)	10.03 (255)	7.12 (181)	7.12 (181)	—	220 (100)
MG-506-1	XA-7048-A	A	coax (0)	7.90 (201)	10.42 (265)	7.12 (181)	7.12 (181)	—	227 (103)

* Integral V-Drive is closed coupled to engine housing/flywheel.
Dimensions may vary with housing adapter or output flange.

Use certified drawings for installation.
Dry weights are approximate and vary by input and ratio.
Specifications are subject to change without notice.

TWIN DISC MG-300, MG-500 and MG-5000 SERIES CONFIGURATIONS (Continued)

TWIN DISC MG-300, MG-500, MG-5000 SERIES CONFIGURATIONS

(Continued)

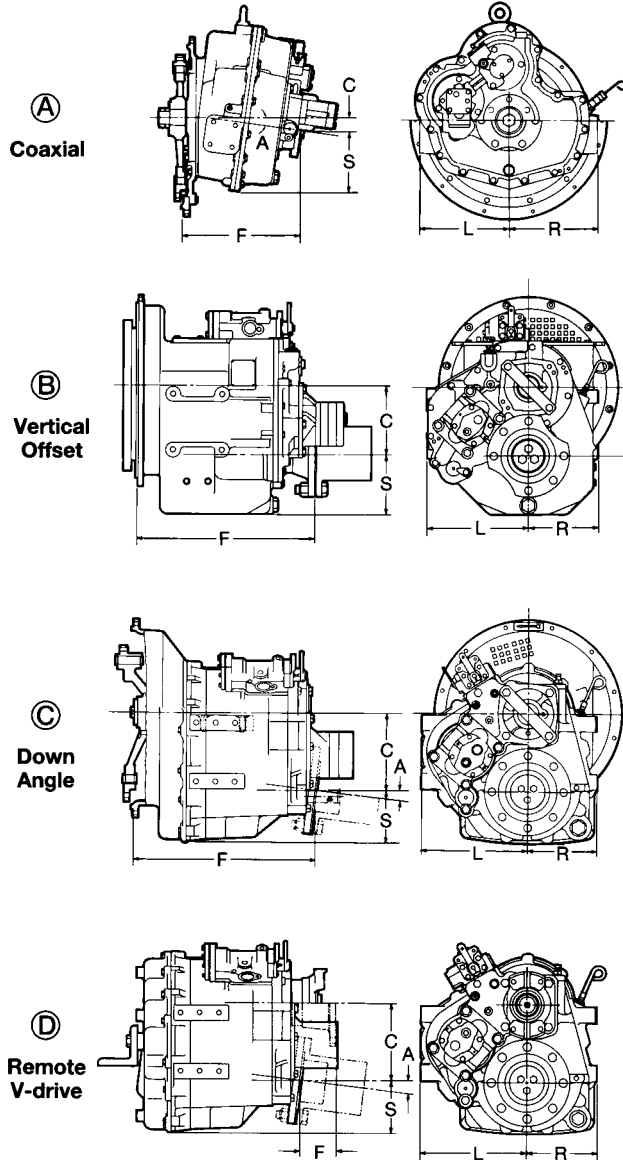

Model	Assembly	Configuration	C (offset) in (mm)	S (sump) in (mm)	F (length) in (mm)	L (mounting pad) in (mm)	R (mounting pad) in (mm)	A degree	W (weight) lb (kg)
MG-5061 SC	PX-11650/-A	B	5.66 (144)	4.84 (123)	13.18 (335)	8.40 (213)	6.15 (156)	—	215 (98)
MG-5061 A	PX-11640/-A	C	5.75 (146)	4.21 (107)	12.53 (318)	8.40 (213)	6.16 (156)	7	210 (95)
MG-5061 V	PX-8735	D	5.75 (146)	4.21 (107)	2.78 (71)	8.40 (213)	6.16 (156)	7	190 (86)
MG-5062 V	PX-11660/-A	D*	13.03 (331)	3.97 (101)	4.00 (102)	8.40 (213)	6.15 (156)	15	312 (142)
MG-5065 SC	PX-11480	B	6.00 (152)	5.22 (133)	13.30 (338)	10.00 (254)	6.50 (165)	—	244 (111)
MG-5065 A	PX-11165	C	6.69 (170)	4.84 (123)	12.97 (329)	10.00 (254)	6.50 (165)	7	244 (111)
MG-5075 SC	PX-11876	A	0.59 (15)	7.00 (178)	14.11 (358)	10.00 (254)	10.00 (254)	—	268 (122)
MG-5075 SC	PX-10680/-A	A	0.59 (15)	7.00 (178)	14.11 (358)	10.00 (254)	10.00 (254)	—	268 (122)
MG-5075 A	PX-10700/-A	A	1.91 (48)	7.00 (178)	13.80 (350)	10.00 (254)	10.00 (254)	7	268 (122)
MG-5075 IV	PX-11530	D*	14.70 (373)	3.93 (100)	2.34 (59)	10.00 (254)	10.00 (254)	15	330 (150)
MG-5082 SC	PX-11250-A	A	0.59 (15)	7.00 (178)	16.24 (413)	10.00 (254)	10.00 (254)	—	298 (135)
MG-5082 A	PX-11040-B	A	2.12 (54)	7.00 (178)	15.97 (405)	10.00 (254)	10.00 (254)	7	298 (135)
MG-5085 SC	PX-9260-B/-C	B	6.00 (152)	5.25 (133)	14.67 (373)	10.00 (254)	6.50 (165)	—	265 (120)
MG-5085 A	PX-9360-B/-C	C	6.69 (170)	4.84 (123)	14.69 (373)	10.00 (254)	6.50 (165)	7	270 (123)
MG-509	X-9816-F	B	6.82 (173)	5.85 (149)	15.62 (397)	10.25 (260)	10.25 (260)	—	572 (259)
MG-509	X-9835	B	9.49 (241)	9.40 (240)	17.38 (441)	11.12 (282)	11.12 (282)	—	712 (323)
MG-5091 SC	PX-10016	B	6.82 (173)	6.22 (158)	16.59 (421)	10.25 (260)	6.94 (176)	—	485 (220)
MG-5091 DC	1002155	B	9.49 (241)	9.60 (244)	18.09 (459)	11.12 (282)	11.12 (282)	—	655 (297)
MG-5090 A	PX-10015	C	7.30 (185)	5.05 (128)	17.07 (434)	10.25 (260)	7.00 (178)	7	475 (215)
MG-5095 SC	PX-11535	B	7.48 (190)	6.14 (156)	17.00 (432)	10.43 (265)	10.43 (265)	—	419 (190)
MG-5095 A	PX-11495	C	7.43 (189)	5.54 (141)	17.00 (432)	10.43 (265)	10.43 (265)	7	407 (185)
MG-5095 RV	PX-11600	D	7.43 (189)	5.54 (141)	2.37 (60)	10.43 (265)	10.43 (265)	7	392 (178)
MG-5114 SC	PX-9785-B	B	7.47 (190)	6.33 (161)	19.00 (483)	11.00 (279)	7.50 (191)	—	447 (203)
MG-5114 SC-HD	PX-11962	B	7.47 (190)	6.33 (161)	19.00 (483)	11.00 (279)	11.00 (279)	—	595 (270)
MG-5114 DC	PX-10250-A	B	10.90 (277)	9.85 (250)	19.03 (483)	11.25 (286)	11.25 (286)	—	800 (364)
MG-5114 A	PX-11915	C	8.00 (203)	5.30 (133)	18.80 (479)	11.00 (279)	8.00 (203)	7	455 (206)
MG-5114 RV	PX-9830-A	D	8.00 (203)	5.25 (133)	2.51 (64)	11.00 (279)	8.00 (203)	7	435 (198)
MG-5114 IV	PX-11920	D*	16.26 (413)	5.75 (146)	2.43 (62)	7.50 (191)	11.50 (292)	14	595 (270)
MG-514C SC	X-9784-C	B	9.32 (237)	9.77 (248)	19.51 (496)	14.75 (375)	12.75 (324)	—	1155 (524)
MG-514C DC	X-9786-C	B	13.29 (338)	12.77 (324)	22.14 (562)	14.00 (356)	14.00 (356)	—	1450 (658)
MG-5135 SC	PX-11590	B	7.87 (200)	7.48 (190)	21.06 (535)	12.01 (305)	12.01 (305)	—	661 (300)
MG-5135 A	PX-11380	C	9.09 (231)	6.28 (160)	20.48 (520)	12.01 (305)	12.01 (305)	10	617 (280)
MG-5135 RV	PX-11945	D	9.09 (231)	6.28 (160)	3.70 (94)	12.01 (305)	12.01 (305)	10	568 (258)
MG-5145 SC	PX-10885	B	8.12 (206)	7.04 (179)	21.05 (535)	12.01 (305)	12.01 (305)	—	716 (325)
MG-5145 A	PX-10830	C	10.40 (264)	6.13 (156)	20.33 (516)	12.01 (305)	12.01 (305)	10	734 (333)
MG-5145 RV	PX-10880	D	10.40 (264)	6.13 (156)	4.93 (125)	12.01 (305)	12.01 (305)	10	650 (295)
MG-520-1HP	XA-7255-B	B	16.44 (418)	16.55 (420)	30.86 (784)	16.00 (406)	16.00 (406)	—	3436 (1560)
MG-5202 SC	1016103-C	B	9.75 (248)	8.75 (222)	23.45 (595)	14.75 (375)	10.50 (267)	—	1275 (580)
MG-5203 SC	1016249-A	B	9.75 (248)	8.75 (222)	23.43 (595)	14.75 (375)	10.50 (267)	—	900 (409)
MG-5204 SC	1016250-B	B	9.75 (248)	8.75 (222)	23.43 (595)	14.75 (375)	10.50 (267)	—	900 (409)
MG-5321 DC	1015339-A	B	17.32 (440)	16.77 (426)	29.83 (758)	17.32 (440)	17.32 (440)	—	3696 (1678)
MG-540	X-9882-C	B	8.08 (205)	13.45 (342)	36.47 (926)	16.00 (406)	16.00 (406)	—	4450 (2019)
MG-5506	00D005604	B	19.29 (490)	19.29 (490)	39.17 (995)	20.08 (510)	20.08 (510)	—	4846 (2200)
MGN-1814 V	DDP007097	B	16.73 (425)	19.69 (500)	55.12 (1400)	27.56 (700)	23.62 (600)	—	6608 (3000)
MGN-1816 V	DDP007098	B	21.26 (540)	22.83 (580)	55.12 (1400)	29.53 (750)	29.53 (750)	—	8370 (3800)
MGN-1817 V	DDP007099	B	26.38 (670)	27.56 (700)	55.12 (1400)	31.50 (800)	31.50 (800)	—	9912 (4500)
MGN-1819 V	PLN005679	B	30.71 (780)	33.46 (850)	55.12 (1400)	37.40 (950)	37.40 (950)	—	TBA (TBA)

* Integral VDrive is closed coupled to engine housing/flywheel. Dimensions may vary with housing adapter or output flange.

Use certified drawings for installation. Dry weights are approximate and vary by input and ratio. Specifications are subject to change without notice.

TWIN DISC MG-6000 and MGX-6000 SERIES CONFIGURATIONS

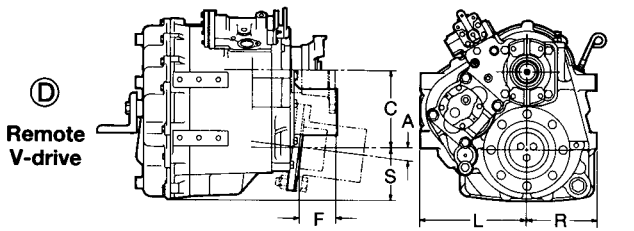
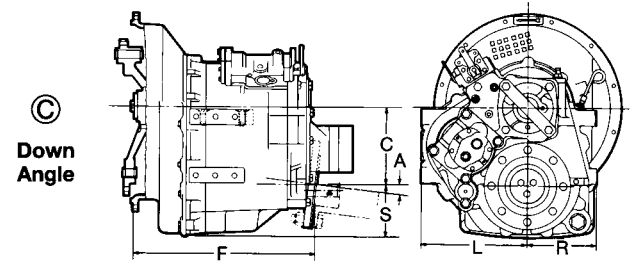
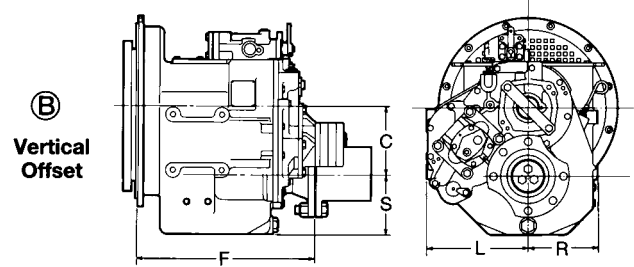
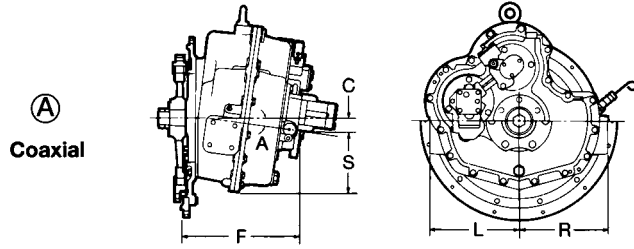

TWIN DISC MGX-6000 (QuickShift®) SERIES DIMENSIONAL DATA

Model	Assembly	Configuration	C (offset) in (mm)	S (sump) in (mm)	F (length) in (mm)	L (mounting pad) in (mm)	R (mounting pad) in (mm)	A degree	W (weight) lb (kg)
MGX-6598 DC	7-40379	B	12.20 (310)	10.83 (275)	23.72 (603)	14.17 (360)	14.17 (360)	—	1278 (580)
MGX-6599 SC	7-40384	B	8.66 (220)	9.29 (236)	23.31 (592)	13.39 (340)	13.39 (340)	—	1084 (492)
MGX-6599 A	7-40263	C	11.70 (297)	6.25 (159)	22.60 (574)	13.39 (340)	13.39 (340)	10	1075 (488)
MGX-6599 RV	7-40336	D	11.70 (297)	6.25 (159)	7.95 (202)	13.39 (340)	13.39 (340)	10	1031 (468)
MGX-6620 SC	7-40337	B	9.25 (235)	9.25 (235)	27.48 (698)	13.39 (340)	13.39 (340)	—	1267 (575)
MGX-6620 A	7-40264	C	12.44 (316)	7.25 (184)	25.70 (653)	13.39 (340)	13.39 (340)	10	1278 (580)
MGX-6620 RV	7-40316	D	12.44 (316)	7.25 (184)	6.57 (167)	13.39 (340)	13.39 (340)	10	1123 (510)
MGX-6650 SC	1002046	B	12.21 (310)	11.81 (300)	30.13 (765)	17.32 (440)	17.32 (440)	—	2205 (1001)
MGX-6690 SC	1020674	B	12.21 (310)	11.81 (300)	30.13 (765)	17.32 (440)	17.32 (440)	—	2205 (1001)
MGX-6848 SC	1020675	B	12.21 (310)	11.81 (300)	30.13 (765)	17.32 (440)	17.32 (440)	—	2205 (1001)
MGX-61000 SC*	1024420	B	14.96 (380)	14.17 (360)	39.08 (993)	19.29 (490)	19.29 (490)	—	1780 (3920)
MGX-61500 SC*	1022390	B	18.11 (460)	15.63 (397)	40.63 (1032)	18.23 (463)	18.23 (463)	—	1920 (4230)

TWIN DISC MG-6000 SERIES DIMENSIONAL DATA

Model	Assembly	Configuration	C (offset) in (mm)	S (sump) in (mm)	F (length) in (mm)	L (mounting pad) in (mm)	R (mounting pad) in (mm)	A degree	W (weight) lb (kg)
MG-6449 A	7-37423	C	10.83 (275)	4.92 (125)	20.83 (529)	12.01 (305)	12.01 (305)	10	757 (344)
MG-6449 RV	7-37431-A	D	10.88 (276)	6.44 (164)	6.32 (161)	12.01 (305)	12.01 (305)	10	782 (355)
MG-6600 DC	7-36712-A	B	14.17 (360)	14.96 (380)	30.87 (784)	14.76 (375)	14.76 (375)	—	1747 (794)
MG-6984 SC	7-37008	B	12.21 (310)	11.30 (287)	27.20 (691)	17.52 (445)	17.52 (445)	—	2628 (1192)
MG-6984 A	7-37028	C	15.04 (382)	8.50 (216)	26.93 (684)	17.52 (445)	17.52 (445)	10	1991 (905)
MG-6984 RV	7-37042	D	15.04 (382)	8.50 (216)	11.82 (300)	17.52 (445)	17.52 (445)	10	2002 (910)
MG-61242 SC	7-37017	B	13.39 (340)	12.17 (309)	29.80 (757)	19.69 (500)	19.69 (500)	—	2310 (1050)
MG-61242 A	7-37046	C	17.52 (445)	9.49 (241)	30.35 (771)	19.69 (500)	19.69 (500)	10	2431 (1105)
MG-61242 RV	7-37049	D	17.52 (445)	9.49 (241)	11.34 (288)	19.69 (500)	19.69 (500)	10	2475 (1125)

* Consult Twin Disc for availability of MGX-61000 SC and MGX-61500 SC, all ratios. Dimensions may vary with housing adapter or output flange.

Dimensions may vary with adapter or output flange. Dry weights are approximate and vary by input and ratio. Use certified drawings for installation. Specifications are subject to change without notice.

TWIN DISC, INCORPORATED

1328 Racine Street • Racine, Wisconsin 53403 USA
Telephone: +1 (262) 638-4000 • Telefax: +1 (262) 638-4480

TWIN DISC INTERNATIONAL SA

Chaussee de Namur, 54
B-1400 Nivelles
Belgium
Telephone: +32 (0) 67 887.211
Telefax: +32 (0) 67 887.333
E-mail: tdbelgium@twindisc.com

TWIN DISC SRL

Via S Cristoforo 131
40017 S. Matteo della Decima (BO)
Italy
Telephone: +39 051 6819711
Telefax: +39 051 6824234
6825814
E-mail: info@technodrive.it

TWIN DISC SRL

Via E.e.P. Salani 1
50050 Limite sull'Arno (FI)
Italy
Phone: +39 0571 979111
Telefax: +39 0571 979143
E-Mail: bcs@bcsmarine.com

TWIN DISC, INC.

Latin America Office
11700 NW 101 Rd. Suite 19
Medley, Florida 33178
USA
Telephone: +1 (305) 887-9050
Telefax: +1 (305) 887-9090
E-mail: eberhardt.erwin@twindisc.com

TWIN DISC (PACIFIC) PTY. LTD.

Brisbane Main Office
40 Telford St.
Virginia Queensland 4014
Australia
Telephone: +61 (7) 3265-1200
Telefax: +61 (7) 3865-1371
E-mail: twindisc.brisbane@twindisc.com.au

TWIN DISC (FAR EAST) LTD.

40 Lok Yang Way
Jurong
Singapore 628643
Telephone: +65 62670800
Telefax: +65 62642080
E-mail: enquiry@twindisc.com.sg

TWIN DISC, INC.

Shanghai Representative Office
Room 2108, Shartex Plaza
88 Zunyi Road (S)
Shanghai, China 200336
Telephone: +86 (21) 6427 3212
+86 (21) 6209 7629
Telefax: +86 (21) 6209 7629
E-mail: tdchina@online.sh.cn

Guangzhou Representative Office
Room 1405, Xingchen Building
172 Huasui Road
Zhujiajiangxincheng
Guangzhou, China 510623
Telephone: +86 (20) 3837 2927
Telefax: +86 (20) 3759 1441
E-mail: jason.yang@twindisc.com.cn

ROLLA SP PROPELLERS SA

Via Roncaglia 6
P.O. Box 109
6883 Novazzano
Switzerland
Phone: +41 (0) 91 695 2000
Telefax: +41 (0) 91 695 2001
E-mail: info@rolla-propellers.ch

TWIN DISC JAPAN

Twin Disc Nico Co. Ltd.
405-3, Yoshinocho 1-chome, Kita-ku
Saitama-shi, Saitama-ken
331-0811
Japan
Phone: +81 (48) 652-8069
Telefax: +81 (48) 665-6695
E-Mail: info@tdnico.com





TWIN DISC, INCORPORATED
RACINE, WISCONSIN, U.S.A.

United States of America • Australia • Belgium
France • Italy • Singapore • Switzerland

WWW.TWINDISC.COM

Bulletin 319-CC-MCT 5M-1/10 Printed in the USA