

MAXIMUM 578 KW (775 HP) @ 2100 RPM [INTERMEDIATE DUTY]**STANDARD EQUIPMENT****MG-5170 DC**

Input coupling 14"/18" torsional type
with torsional stop standard

Oil pressure gauge

Oil strainer and oil filter

RPM pickup ports

SAE housings no. 1 and 0

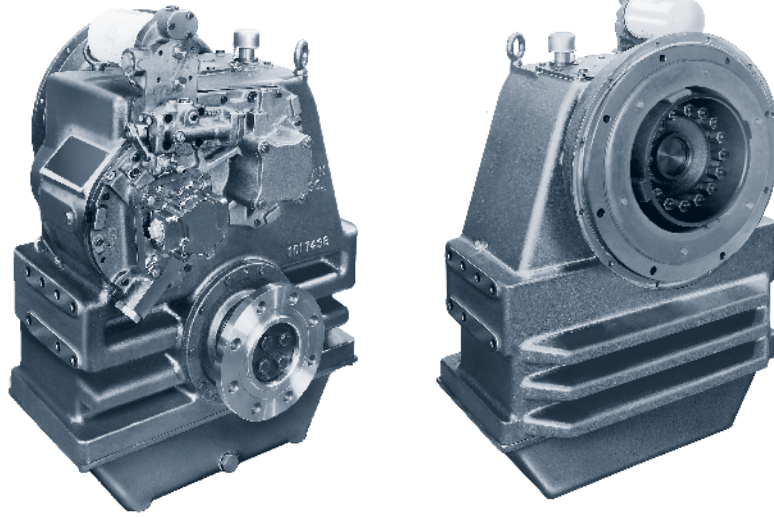
**OPTIONS**

Companion flange

Electric selector valve (12V or 24V)

Mounting brackets

Oil temperature gauge

Raw/fresh water heat exchangers

Remote mounted filter

Trolling valve

PTOs – Run engine direction and engine speed

Live SAE C – 592 N•m (437 lb-ft)

Live SAE C-C – 1186 N•m (875 lb-ft)

With hydraulic disconnect clutch SAE C – 592 N•m (437 lb-ft)

With hydraulic disconnect clutch SAE C-C – 1186 N•m (875 lb-ft)

Weight (dry weight – alloy housing)

MG-5170 DC**X****X****X****X****X****X****X****X****X****850 kg**

Contact Twin Disc for Survey Society Approvals and Classifications.

Specifications subject to change without prior notice in the interest of continual product improvement.

INPUT RATINGS – KILOWATTS (KW) (HORSEPOWER [HP])*

MG-5170 DC	Reduction Ratios :1	Continuous Duty	Medium Duty	Intermediate Duty	Max rated input speed and min. engine low idle speed RPM
		@ 1800 RPM	@ 1800 RPM	@ 2100 RPM	
	4.06, 4.50, 5.03, 5.95	507 kW (680 hp)	537 kW (720 hp)	578 kW (775 hp)	2500 max. 450 min.
	6.53, 6.95	459 kW (615 hp)	459 kW (615 hp)	545 kW (731 hp)	

* Ratings shown for use with standard right hand rotation engines.

SERVICE CLASSIFICATION DEFINITIONS

Pleasure Craft [PC]: Up to 500 hours/year, low load factor usage planing hull vessels where typical full engine throttle operation is less than 10% of total time. The balance of operation at 80% of full engine throttle or less. Marine transmissions for use in long range pleasure cruisers, sportfish charter boats/patrol boats do not qualify for Pleasure Craft Service.

Note: Some revenue producing applications such as Planing Hull Bristol Bay Gillnetter do qualify under Pleasure Craft rating definition.

Light Duty [LD]: Relatively low hour usage (less than 1500 hours per year) where full throttle operation is 2 hours out of 12.

Typical applications include planing hull vessels such as fire boats, sportfish charter boats, and patrol/custom boats. This rating is also applicable to some bow and stern thruster applications.

Intermediate Duty [ID]: Hour usage of up to 2000 hours/year (for models MG-5114 Series and smaller) and up to 3000 hours/year (for models larger than MG-5114 Series) with 50% of the operating time at full engine rating.

Typical applications include planing hull vessels such as ferries, fishing boats, some crew boats, and some displacement hull yachts as well as some bow and stern thruster applications.

Medium Duty [MD]: Hour usage of up to 4000 hours/year with up to 80% of operating time at full engine power. This duty classification is for usage where some variations in engine speed/power occur as part of normal vessel operation.

Typical vessels include mid-water trawlers, crew/supply boats, ferries, and some inland water tow boats.

Continuous Duty [CD]: For use in continuous operation with little or no variation in engine speed/power setting.

Typical vessels include fishing trawlers, tow/tug boats and ocean going vessels.

Important Notice: Torsional Vibration: Disregarding propulsion system torsional compatibility could cause damage to components in the drive train resulting in loss of mobility. At minimum, system incompatibility could result in gear clatter at low speeds.

The responsibility for ensuring that the torsional compatibility of the propulsion system is satisfactory rests with the assembler of the drive and driven equipment.

Torsional vibration analysis can be made by the engine builder, marine survey societies, independent consultants and others. Twin Disc is prepared to assist in finding solutions to potential torsional problems that relate to the marine transmission.

Twin Disc, Incorporated reminds users of these products that their safe operation depends on use in compliance with engineering information provided in this bulletin. Users are also reminded that safe operation depends on proper installation, operation and routine maintenance and inspection under prevailing conditions. It is the responsibility of the user (and not Twin Disc, Incorporated) to provide and install guards or safety devices which may be required by recognized safety standards or by the Occupational Safety and Health Act of 1970 and its subsequent provision.

MG-5170 DC

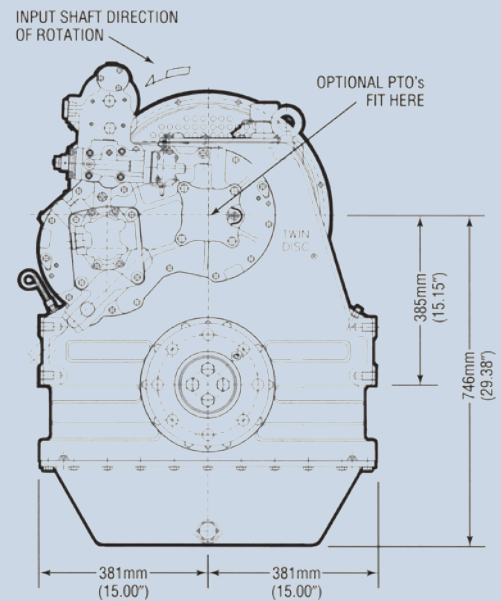
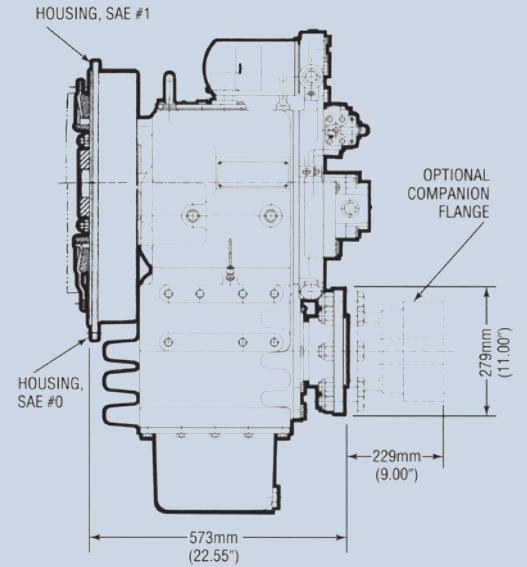

Twin Disc, Incorporated
Racine, Wisconsin 53403 U.S.A
Phone +1-262-638-4000
Fax +1-262-638-4482
www.twindisc.com