

DJ330 TECHNICAL SPECIFICATIONS



UNIT DETAILS

Maximum Rec. Continuous Power:	Up to 3090skW (4150shp)
Maximum Rec Impeller speed:	1020rpm
Dry Weight:	3250 kg (including standard reverse controls)
Total Entrained Water:	1600 kg (typical-dependant on intake geometry)
Loss of buoyancy	1145 kg (water inside transom)
Corrosion Protection:	Cathodic with Anodes
Design Standard:	To international authority standards

CONSTRUCTION DETAILS

Impeller:

Diameter:	33 inch (838mm)
No of Stages/Configuration:	Single Stage – Axial / Mixed flow pump
Standard Rotation:	Anti-clockwise (Looking forward from stern)
Impeller Material:	Cast CF8M Stainless Steel

Pump Assembly:

Impeller Casing Material:	AISI 316 Stainless Steel
Discharge Nozzle Material	Cast CF8M & AISI 316 Stainless Steel

Steering System:

Description	Balanced nozzle
Operation	Hydraulic with Inboard tiller actuation
Steering Bowl/Nozzle Material:	Cast ASTM A356 Aluminium Alloy
Nozzle Diameter Range:	425-475mm

Reverse System:

Description	Split Duct Type – “High Thrust”
Operation	Hydraulic with Dual Inboard cylinder actuation
Reverse duct material	Cast ASTM A356 & 5083 grade plate aluminium

Shaft Assembly:

Main Shaft Material:	Stainless Steel Grade SAF 2205
Rear Bearing:	Water Lubricated Cutlass Bearing
Main Bearing:	Spherical roller Thrust Bearing Spherical roller Bearing - Radial
Lubrication	Oil lubrication with circulating pump
Shaft Seal:	Face type Mechanical Seal
Coupling Flange:	GWB Series to suit application
Shaft Angle	0 degrees standard – Custom shaft angles available

Intake Body:

Material:	5083 grade plate aluminium
Inspection Opening:	Inboard
Intake Grate:	Removable Stainless Steel Bars

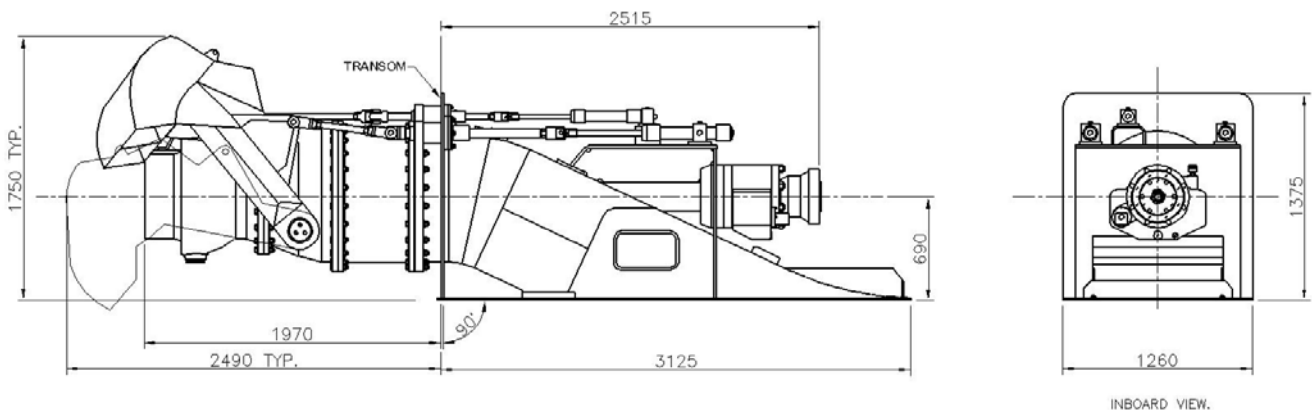

Due to our policy of continuous Research & Development, we reserve the right to change the specifications without notice