



Engineered by HJS/DES

**VERT**  
approved

## **MANN+HUMMEL SMF®-AR**

**Diesel particulate filter with active regeneration**



# MANN+HUMMEL SMF®-AR

The SMF®-AR diesel particulate filter is designed for applications in the low to medium power output range with low or variable power consumption. Its high performance is based on the many years of experience MANN+HUMMEL

has in the field of filtration technology. This complete system consists of a filter plus software, electronics and sensors and is fully automatic. The SMF®-AR has active regeneration, which means that the soot burn-off is triggered as

soon as the filter has a full load of soot particles. Operators and the environment both benefit from this advanced technology.



## Advantages

- Low running costs via continuous operation of the machine (no downtime). The active regeneration monitors and regenerates the whole system.
- Low service costs through extremely long service intervals (depending on the application up to 2,000 hours) due to a very high ash holding capacity
- Easy to clean without the need for additional and expensive cleaning cabins
- Low maintenance costs through durable sintered metal filter. It is seldom necessary to replace the filter during the life of the engine.
- Sintered metal technology with a particle separation efficiency higher than 99% equals high efficiency
- Considerable reduction of NO<sub>2</sub>. Depending on the application by up to 70%.
- Safe and proven investment
- Flexible use via very compact design and wide range of exhaust temperatures. Other applications which cannot be operated with passive systems present no difficulty for the active SMF®-AR. The use of sintered metal technology enables achievement of exhaust backpressures which correspond to the specifications of the engine producer and therefore represent no risk to the engine.
- Conventional ceramic filters operate with considerably higher backpressures which reduce the engine output and cause increased fuel consumption (see picture)

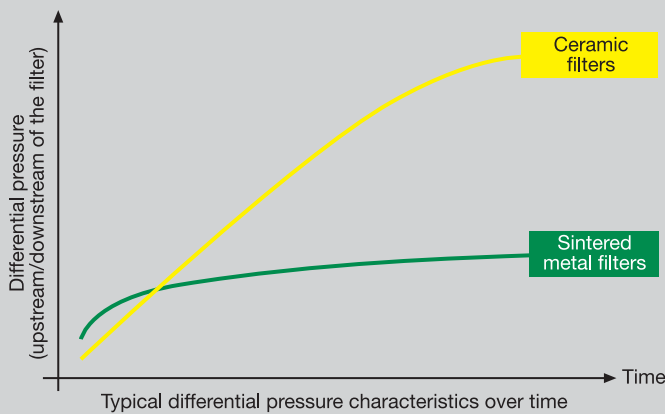

# The powerful solution up to 130 kW

## Typical applications

Diesel applications in the low to medium power output range with low or variable power consumption (e.g. forklifts, mini excavators, wheel loaders up to 130 kW, compressors, construction machines, tractors, agricultural machines)



Engineered by HJS/DES

## System components

- Filter module with heating element for regeneration
- Input/output module including seals and clamping rings for easy assembly
- Electronic control unit with display for regeneration with optical warning (incl. pressure sensor, temperature sensor, airflow meter)
- Cable harness for complete system provided
- Automatic additive dosing with level control and tank for additive
- Please state cable length for power supply must be stated when ordering (0.6 m, 1 m, 2 m, 3 m)
- Detailed documentation included
- SMF®-AR diesel additive DT7

## Accessories

- Extension for heating cable 1 m, 2 m or 3 m (max. length 4.5 m)
- Insulation for filter module for protection against heat-sensitive components in engine compartment (if present)
- Mounting fittings for filter module

## Options

- The input/output module is available as an axial or radial version
- Power supply cable length must be specified (0.6 m, 1 m, 2 m or 3 m)

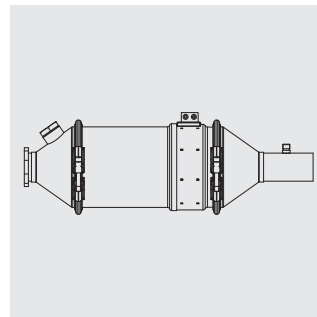

Axial version

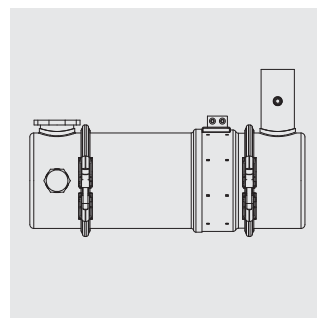

Radial version

# Specifications

## Overview of variations

Output [kW]	Filter [m <sup>2</sup> ]	Øexternal [mm]	Length* [mm]	Separation efficiency [quantity of particles**]	Weight*** [kg]
<25	1.2	182	372	99%	7.7
20-30	1.8	182	452	99%	10
30-50	2.7	182	584	99%	14
50-75	3.8	232	629	99%	21
75-100	5.4	325	687	99%	42
100-130	8.1	325	822	99%	51

\* Details for radial – radial version

\*\* Quantity of particles in size range 20-300 nm

\*\*\* complete filter

<b>Soot load</b>	20-30 g/m <sup>2</sup>
<b>Max. power consumption of heater: 1.2-3.8 SMF®-AR</b>	1.2 kW
<b>Max. power consumption of heater: 5.4-8.1 SMF®-AR</b>	2.4 kW
<b>Filter material</b>	high-temperature chromium nickel steel
<b>Filter housing material</b>	1.4301
<b>Surface temperature without insulation</b>	max. 600°C
<b>Surface temperature with insulation</b>	max. 100°C
<b>Ash holding capacity</b>	max. 50 g/l filter volume
<b>Separation efficiency (particle concentration in range 20-300 nm)</b>	> 99%
<b>Separation efficiency (relating to soot)</b>	> 85%
<b>Duration of the regeneration</b>	3-5 minutes
<b>Additive consumption</b>	1 l / 1670 l diesel
<b>Additive substance content</b>	Organometallic iron compound
<b>Hazardous material class</b>	Xn; R48/22, R65, R66

## Legal conditions

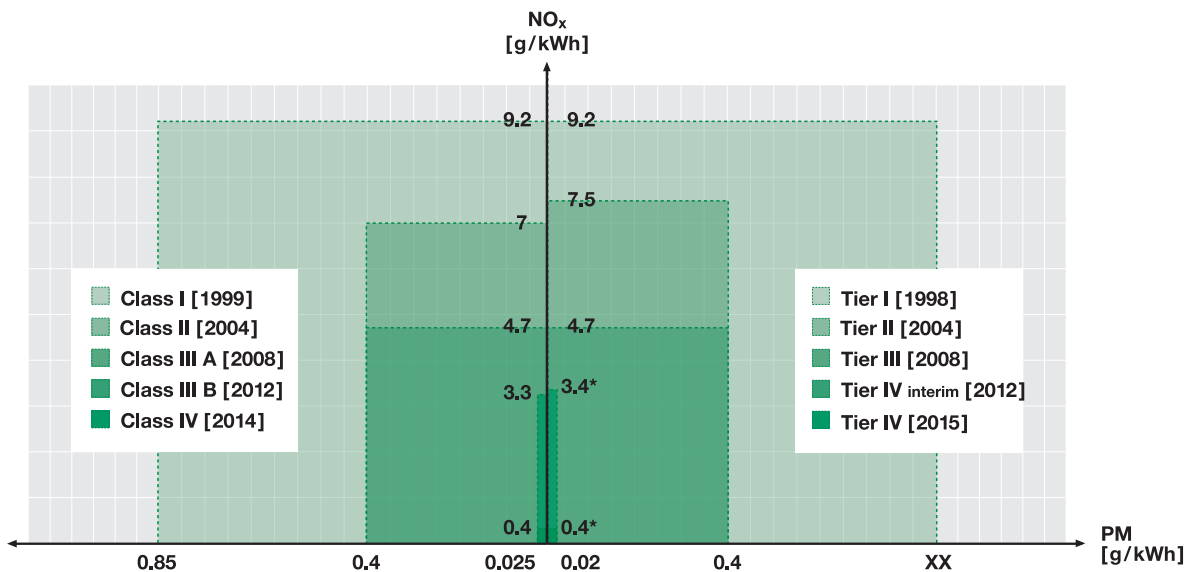

### EU – Non-road

EU directive 97/68/EU  
for engine-power class 37-75 kW

### USA – EPA Non-road

regulations 40 CFR 89, 40 CFR 1039 and  
40 CFR 1068 for class 37-75 kW

# Mode of operation of the MANN+HUMMEL SMF®-AR

The SMF®-AR diesel particulate filter regenerates fully and automatically without machine downtimes. Pressure and temperature sensors together with an airflow meter monitor the load level of the filter and trigger regeneration according to an adjustable strategy. During regeneration a heating element uses electrical energy without direct contact to ignite the soot which then completely burns off over the whole filter.

The electrical energy required for regeneration is so low that it can be taken from the

on-board supply without any problems. The soot burn-off has no negative effect on the exhaust emission or performance of the machine.

In order to ignite the soot electrically without direct contact, the normal ignition temperature of approx. 600°C is reduced to approx. 400°C with the aid of an additive. The additive is automatically introduced with the correct dose to the diesel fuel tank from a separate tank.

During combustion in the engine the additive bonds

to the soot. Subsequently, in the filter, this ensures easy ignition of the soot by the heating element. The performance and chemical composition of the additive used corresponds to additives which have already been in use for some years in cars. These additives do not affect or harm the engine.

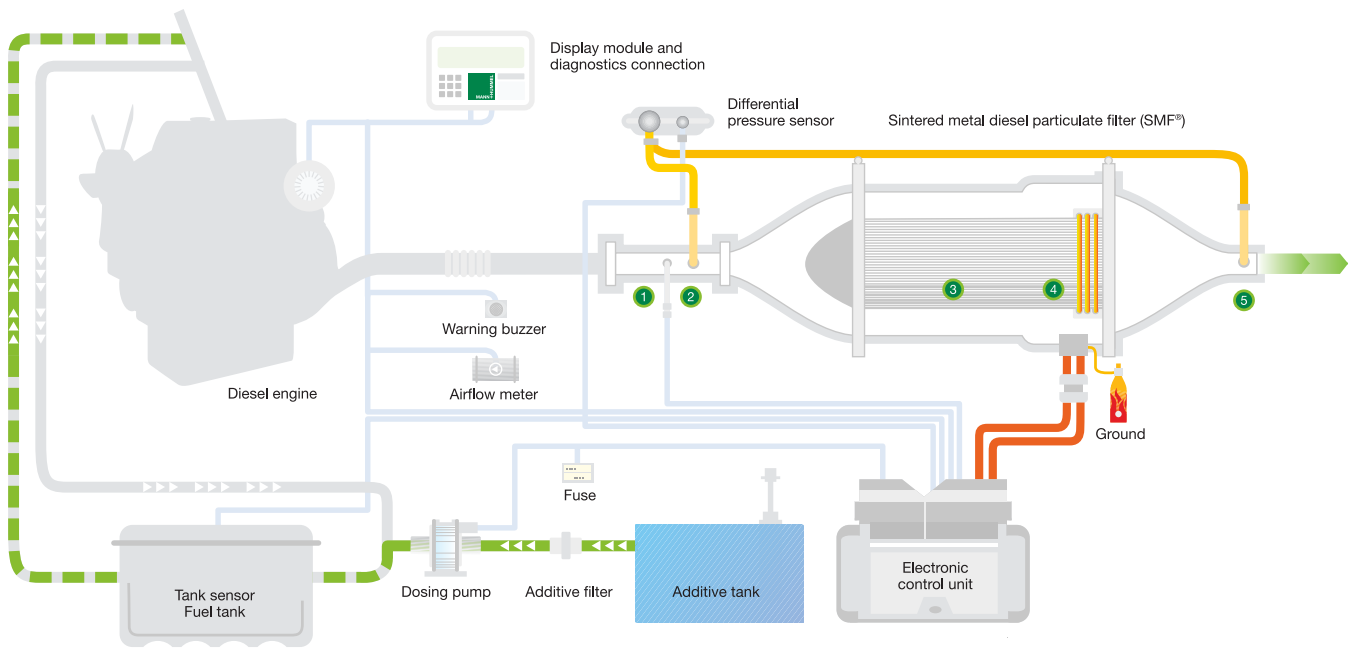

- |                                   |               |  |                       |
|-----------------------------------|---------------|--|-----------------------|
| Measuring and control cable       | Additive pipe | Temperature sensor                               | Sintered metal filter |
| Differential pressure measurement | Power supply  | Pressure measuring position upstream of filter   | Heating elements      |
|                                   |               | Pressure measuring position downstream of filter |                       |

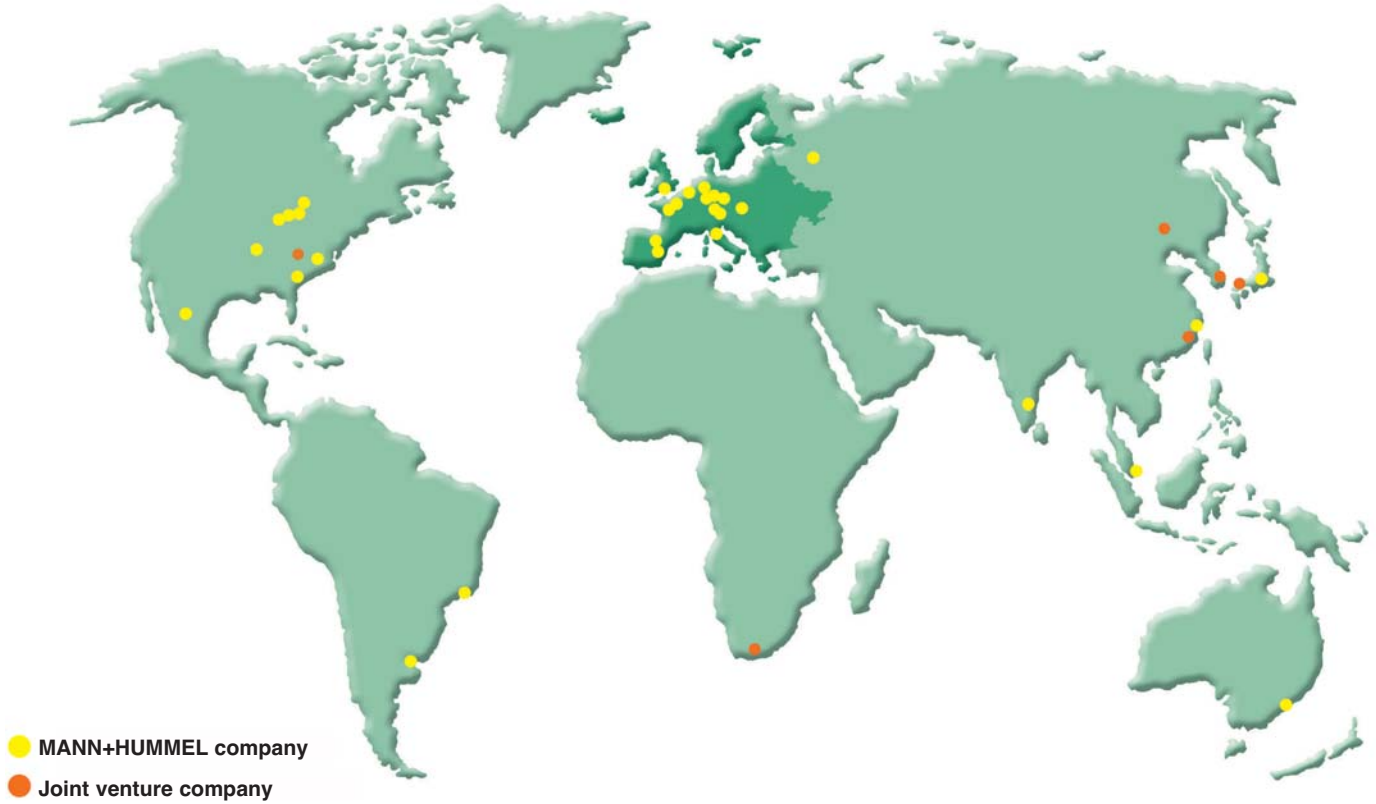

## MANN+HUMMEL Group

The MANN+HUMMEL Group is an international company with its headquarters in Ludwigsburg, Germany. The group employs more than 11,500 people worldwide at more than 41 locations.

The company develops, produces and sells technically complex components and systems for the automotive

industry and many other fields. A key area is high quality filtration products for vehicles, engines and industrial applications. The OEM business with global market leaders and producers of vehicles, machines and installations defines the quality and performance of the products. Filters for the international aftermarket are sold

under a variety of international brands as well as under the MANN-FILTER brand.

### MANN+HUMMEL Industrial Filters

The Industrial Filters Business Unit has its headquarters in Speyer, Germany. The business unit is specialized in meeting the special require-

ments of off-highway vehicles and engine applications, compressed air and vacuum technology, mechanical engineering and plant construction.

MANN+HUMMEL Industrial Filters offers high performance for these fields and other fields which have a requirement for the filtration and separation of air, gas and liquids.



**MANN+HUMMEL GMBH**, Business Unit Industrial Filters  
 Telephone +49 (62 32) 53-80, Fax +49 (62 32) 53-88 99  
 E-Mail: [si.retrofit@mann-hummel.com](mailto:si.retrofit@mann-hummel.com), Internet: [www.mann-hummel.com](http://www.mann-hummel.com)