

Industrial Rental Towable Generator

Genset Ratings



Pictures may include optional equipment and/or accessories.
Generator available with or without trailer

Model: HRJW 35 T6

Ratings Range - 60Hz Operation
1,800 rpm Diesel

Standby	kW	30
	kVA	37
Prime	kW	26
	kVA	33

Sound Attenuation:
at 7m / 23 ft **63 dBA**

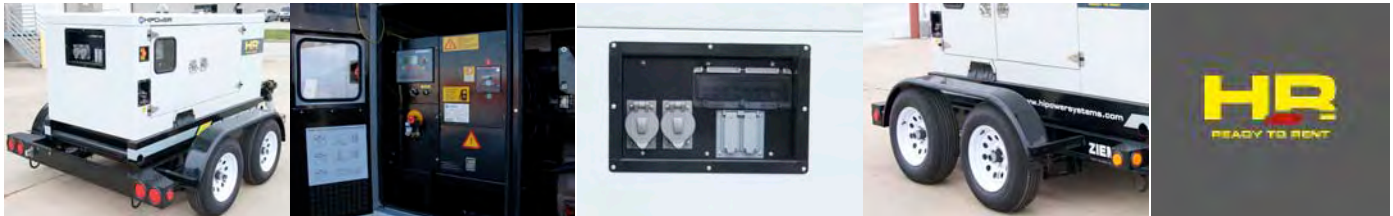

Key features

- HIPOWER rental generators are an efficient, reliable and versatile source of power designed to operate in the most extreme working conditions. An unique combination of innovative materials and design features combine for easy user operation and dependable power you can rely on.
- The Genset features a heavy-duty John Deere 4 cycle diesel engine certified by the Environmental Protection Agency (EPA) to conform to Tier 3-4 Interim non-road emissions regulations, an AC high capability alternator regulated by a precise Automatic Voltage Regulator controlled and protected by our own auto-start CEM7 control panel available CANBUS communications including a powerful microprocessor and easy user programming. A heavy-duty constructed chassis supports the complete set. The generator is protected by a best-in-class sound attenuated enclosure designed for durability and extreme application.

- Engine - generating set tested to ISO 8528-5.
- The Genset engine is certified by the Environmental Protection Agency (EPA) Tier 3-4 Interim non-road emissions regulations.
- The brushless, single bearing, 4 poles, 12-wire generator end, with automatic voltage regulator has broad range reconnectability.
- The Genset is CSA certified.
- Global product support.
- Operations and maintenance manuals.
- 1 Year Standard Warranty. Extended warranties are also available.



Industrial Rental Towable Generator



Model: HRJW 35 T6

Standard features

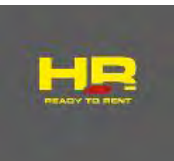

Engine

- Industrial grade Tier 3-4 Interim John Deere diesel Engine, 4 stroke, water cooled, provided with:
- Electric start 12V.
- Radiator with pusher fan.
- Standard water separator not visible level fuel filter.
- Secondary water separator fuel filter.
- Electronic governor.
- HWT/LOP senders.
- Heavy duty 2-stage air filter with service indicator.
- Hot & rotating components (exhaust, fan,...) protections and radiator guards.
- Oil drain hand pump
- Spin type fuel and oil filters.

Alternator

- Self excited, self regulated alternator.
- Insulation class H, IP23 Protection.
- Automatic Voltage Regulator (AVR-EBS) (+/-1 %).
- Vacuum impregnation.
- Permanent Magnet Generator (PMG).

Control Panel

- Digital microprocessor based control panel with remote start capability.
- CEM7 Auto-start control panel (2 wires).
- **Engine protections:** High coolant temperature **(A)**, High coolant temperature by sensor **(W)**, Low engine temperature by sensor **(W)**, Low oil pressure **(A)**, Low coolant level **(A)**, Unexpected shutdown, Fuel level **(W)**, Stop failure, Battery voltage failure **(W)**, Battery charging alternator failure **(W)**, Overspeed **(A)**, Underspeed **(A)**, Start failure, Emergency stop.

- **Alternator protections:** Over frequency **(A)**, Under frequency **(A)**, Over voltage **(A)**, Under Voltage **(A)**, Short-circuit **(A)**, Unbalanced voltage **(A)**, Incorrect phase sequence **(A)**, Reverse power **(A)**, Overload **(A)**.
- **Genset readings:** Voltage among phases, Voltage among phases and neutral, Amperage, Frequency, Apparent power(kVA), Active power (kW), Reactive power (kVAR), Power factor.
- **Engine readings:** Fuel level(%), Battery voltage, R.P.M, Battery charge alternator voltage, Coolant temperature **(1)**, Oil pressure **(1)**.
- **Digital Metering:** Total hour counter, Partial hour counter, kW meter, Starts valid and Starts failure counters, Maintenance.
- **Communications (optional):** RS232, RS485, Modbus, CCLAN, Software for PC, Analog modem, GSM/GPRS modem, Remote screen, Tele-signal.
- **Other features:** Alarms history, External start, Start inhibition, Start under EJP normative, Pre-heating engine control, Genset contactor activation, Fuel transfer control, Engine temperature control, Manual Override, Programmable alarms, Genset start function in test mode, Programmable outputs, Magnetic Pick-up control.
- **Multilingual capability**
- Remote Communications to our **RAM7** Remote Annunciator Module.
- **NFPA110** Level Compatible.
- On/Off Switch.
- Emergency Stop Button.

NOTES :

- ★ **All the protections are programmable to carry out "Warning Alarm without engine stop" or "Alarm with Engine Stop (with or without cooling cycle)".**
- ★ **(A)** Alarm with Engine Stop.
- ★ **(W)** Warning Alarm without Engine Stop.
- ★ **(1)** Sensor installation necessary



Standard features

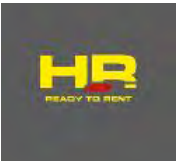

Power Panel

- 3P Main Line Circuit Breaker for overload protection (UL listed)/ CSA 22.2).
- Main bus / Hardwire connection panel with safety protection. (open thermal magnetic protection and alarm).
- Battery disconnect switch.
- Fuel cut-off solenoid and safety switches.

Control Panel BOX

- Auxiliary socket box IP67, with individual breaker protection and 2 GFCI DUPLEX 20A 125VGFI for 110v duplex and 2 TWIST-LOCK 50A 2P+N+G.
- Direct access to auxiliary sockets with suitable protection.
- Voltage selector switch. Lockable, with 3 positions (3phase 277/480V - 3phase 120/208V - 1phase 120/240V).

Electric Equipment

- Battery charging alternator.
- Gel type, heavy-duty Starting battery(s) installed and connected to the engine include cables and rack.
- Ground connection prepared for ground spike (not supplied).

Chassis

- Heavy duty skid base with forklift pockets and drawbars.
- Extended run time high capacity fuel tank.
- 110% spill containment for engine oil, coolant and fuel spills.
- Easy access for chassis cleaning and fast draining of fuel tank.

Industrial Rental Towable Generator



Model: HRJW 35 T6

- Oversized chassis to protect canopy with skids for dragging embedded and Forklift pockets for easy transport.
- Vibration isolators between chassis and generator.
- External fuel tank filling (lockable fuel cap)
- Chassis ready for mobile kit installation. (see mobile kits options).

Enclosure

- Heavy duty sound attenuated canopy made with high quality 11 gauge steel.
- Powder coat paint which exceeds 1,000 hour salt spray test.
- Stainless steel hardware and fasteners.
- Ultra silent all weather enclosures with Rock-Wool insulation and curved edges with minimum outside fasteners.
- Reinforced Single eye lifting point.
- Fuel tank external filling system (lockable filler cap).
- Emergency stops (double protection for emergency stop; inside on control panel + external on canopy).
- Door with window to view control panel.
- Easy access to radiator fill through roof on enclosure.
- Outlet for power cables.
- Recesses provision for quick release couplings (external fuel supply).

Exhaust

- Steel residential silencer of -35dBA attenuation, with rain cap.



Optional features

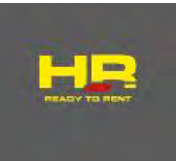

Engine (optional)

- Water Jacket Heater
- Low coolant level sensor.
- Secondary water separator fuel filter - RACOR type (Decanting filter with water detection kit, alarm signal and sensor contact).
- Heavy duty, three stage air filter with service indicator.

Alternator (optional)

- Anti-condensation heater.

Electric Equipment (optional)

- Battery isolator.
- Automatic battery chargers.

Power Panel (optional)

- MPS - Multiple Parallel System.
- Multiple genset paralleling in three different voltages. (120/240 1Ph, 120/208V 3Ph or 277/480V 3Ph) achieved through the voltage selector switch.

Control Panel BOX (optional)

- Camlocks.

Electronics (optional)

- Remote Annunciator Module RAM7 to meet NFPA 110 installation.
- Digital timer.
- CANBUS - LAN, converter.
- CANBUS - USB, converter.
- Communication modules for tele-control.
- Transfer switch and MPS paralleling control panel.

Industrial Rental Towable Generator



Model: HRJW 35 T6

- Multiple remote annunciation options (CAN/USB, GSM, RS232, RS485..).

Chassis (optional)

- Leakage detector sensor.

Fuel System (optional)

- Three way fuel valve with quick disconnect fittings.
- Automatic fuel transfer pump.

Trailers (optional)

- Road towing trailers to DOT standards.

Industrial Rental Towable Generator

Model: HRJW 35 T6

GENSET RATING											
GENSET Model	ENGINE Model	ALTERNATOR Model	VOLTAGE L-L	Ph	Hz	150°C RISE STANDBY RATING			125°C RISE PRIME RATING		
						kW	kVA	Amps L-L	kW	kVA	Amps L-L
HRJW 35 T6	4024TF281 - 36	PI 144 G	120	1	60	17	21	2x89	16	20	2x82
			240	1	60	17	21	89	16	20	82
			208	3	60	28	36	99	26	33	90
			240	3	60	30	38	90	26	33	78
			480	3	60	30	38	45	26	33	39

ENGINE SPECIFICATIONS		
Manufacturer		JOHN DEERE
Engine model		4024TF281 -36
EPA Certification for:	Stage	Tier 4
Rated	RPM	1,800
Nominal Power (PRIME)	kW - HP	32 43
Nominal Power (STANDBY)	kW - HP	36 49
Engine type		Diesel 4 stroke
Inyection type		DIRECT
Aspiration type		TURBO CHARGED
Cylinder arrangement		4 - L
Bore and stroke	(mm) - In	(86 x 105) 3.4 x 4.1
Displacement	L - in3	2.4 149
Cooling system		Liquid (water+50%paraflu11)
Governor Type		electronic
Make		c
Standard		c
Starting voltage	Vcc	12
Air cleaner type		Medium duty w/double cartridge
Compression ratio		20.5 : 1

AMPERAGE	
1 Phase 120V	2x82 Amps
1 Phase 240V	82 Amps
3 Phase 208V	90 Amps
3 Phase 240V	78 Amps
3 Phase 480V	39 Amps
Main Line Circuit Breaker Rating	100 Amps

ALTERNATOR SPECIFICATIONS	
Manufacturer	Stamford
Model (480V)	PI 144 G
Alternator Type	4 poles, rotating field
Excitation system	
Exciter Type	EBS
Leads: quantity, type	12, reconnectable
Stator Pitch	2/3
Insulation system	
Material	Class H
Temperature rise	150°C Standby 125°C Prime
Bearing: quantity, type	Single bearing sealed
Coupling	Flexible disc
Amortisseur windings	Full
Automatic Voltage regulator	
PMG regulator or EBS	EBS (Excitation Boots System)
Voltage regulation, no load to full load	
PMG regulator	+/-1%
Load acceptance	100% of rated standby current
Unbalanced load capability	
Subtransient Reactance	
480V	12%
TIF	<50
Line Harmonics	5% Maximum
Peak motor starting kVA:	30% dip
480V	



Industrial Rental Towable Generator

 **Model: HRJW 35 T6**

ELECTRICAL SYSTEM		12V
Battery charging alternator:		
Ground (negative/positive)		Negative
Volts (DC)	V	12
Ampere rating	Amp	70
Starter motor rated voltage (DC)	V	12
Starter motor rated	kW	2.02
Starter motor rated	HP	2.75
Battery recommendations		
Quantity & Min. Amps rating	Amp	1 x 92
Min. Cold Cranking Amps	Amp	750
Battery Voltage (DC)	V	12

FUEL SYSTEM		
Recommended fuel		#2 Diesel
Fuel supply line. min. ID	mm - in	11 0.44
Fuel return line. min. ID	mm - in	6 0.24
Fuel pump Type		Engine Driven
Max. Lift fuel pump	m - ft	3 9.84
Max. Flow to pump	(l/h) - gal/h	98.8 26.1
Fuel filter		
Secondary filter		5µm @ 98% Eff.
Secondary Water Separator		Included
Primary filter		
Primary Water Separator		

		PRIME		STANDBY	
		l/h	gal/h	l/h	gal/h
100% Load	l/h - gal/h	9.5	2.5	10.6	2.8
75% Load	l/h - gal/h	7.2	1.9	7.8	2.1
50% Load	l/h - gal/h	4.7	1.2	5.3	1.4
25% Load	l/h - gal/h	2.4	0.6	3.2	0.8

EXHAUST SYSTEM		PRIME	STANDBY
Exhaust manifold type		Dry	Dry
Exhaust outlet diameter			
Sound Attenuated version	mm - In	65 - 2.56	
Max. Exhaust temp. at full load	°C	517	552
	°F	963	1026
Exhaust Gas Flow	kg/h - Lb/h	186.48 - 411.12	201.6 - 444.45
	(m3/min) - ft3/min	(7.4) - 261	(8.0) - 283
Evacuated by the exhaust heat	kcal/kWh - kcal/kWh	0.00 - 920.15	
Maximum allowed back pressure	(mm/H2O) - inH2O	762 - 30	
	(kPa) - inH2O	7.5 - 30	

COOLING SYSTEM		
Engine cooling air flow	m3/s - ft3/s	2.6 - 92.0
Generator cooling air flow	m3/min - ft3/min	1.2 - 41.3
Total cooling air flow (engine + generator + combustion)		
Sound Attenuated version	m3/min - ft3/min	322.0 - 11,371.3
Total cooling capacity	l - gal	418.0 - 14,761.5
Antifreeze recommended	l - gal	12.2 - 3.2

LUBRICATION SYSTEM		
Oil Filter: quantity. type		1 x Cartridge
Oil pan capacity	l - gal	7 - 1.85
Oil pan capacity with filter	l - gal	5 - 1.32
Oil cooler		Water Cooled
Recommended Oil		15W-40 or API CI-4 PLUS o CI-4
Specific oil consumption full load	% fuel	<0.1%
Oil Press	(psi) - kPA	43 - 296

VENTILATION REQUIREMENTS		
Air requirement for combustion at 100% load/rated speed	m3/h - ft3/h	180 - 6360
Cooling airflow	m3/h - ft3/h	- - -
Heat rejected to ambient:		
From engine	kW - btu/min	25 - 1412
From alternator	kW - btu/min	0.92 - 52



Control & Power Panel

1. **CM Control Panel.**
 - ✓ CEM7 Auto-start control panel.
 - ✓ On/Off Switch..
 - ✓ Emergency Stop.

2. **CP Power Panel.**
 - ✓ Main Line Circuit Breaker for overload protection (UL listed / CSA22.2).
 - ✓ Main bus /hardwire connection panel with safety protection.
 - ✓ Fuel cut-off solenoid and safety switches



Pictures may include optional equipment and/or accessories.

Control Panel BOX

1. **Auxiliary socket box IP67 with:**
 - ✓ Individual breaker protection for sockets
 - ✓ 2 GFCI duplex 20A 125VGFI for 110v duplex
 - ✓ and 2 TWIST-LOCK 50A 2P+N +G

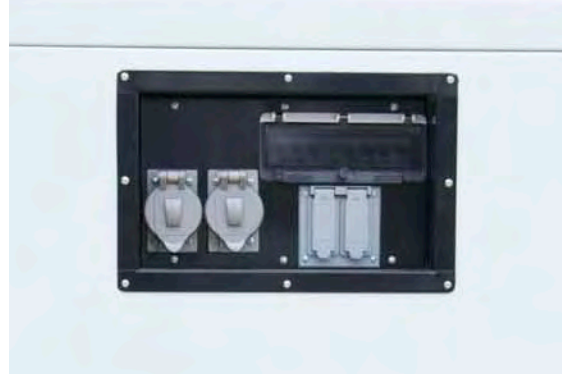

Pictures may include optional equipment and/or accessories.

Optional features Control Panel BOX

1. Camlocks

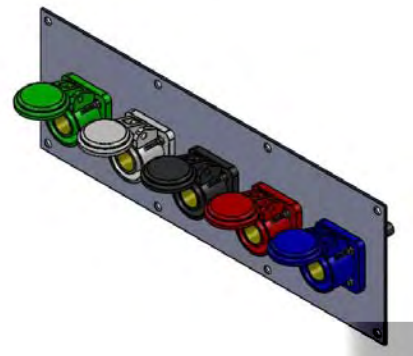

Voltage Selector Switch

1. Voltage selector switch 3 positions padlockable (12h / 09h/ 03h).
 - ✓ High (Series) Wye 480/277V 3Ph Y.
 - ✓ Low (Parallel) Wye 208/120V 3Ph YY.
 - ✓ Low (Parallel) Zig Zag 240/120V 1Ph ZZ.
2. 7 contact stages, 14 contacts.
3. Switching angle 90°.

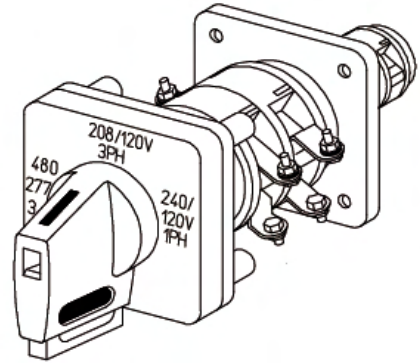

AC Generator Startor Winding connected for 2Phase
+Neutral Parallel Zig-Zag: 120/240 VAC 60Hz

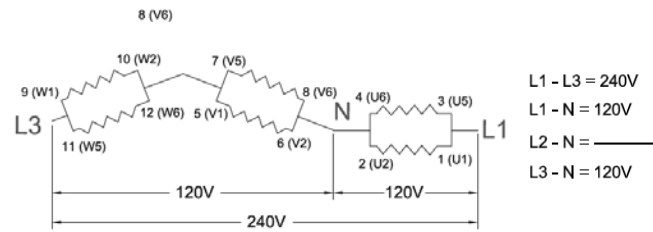
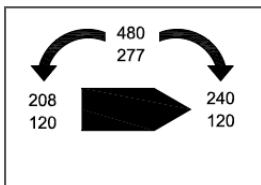

AC Generator Startor Winding connected for
3Phase Low Wye: 208/120 VAC 60Hz

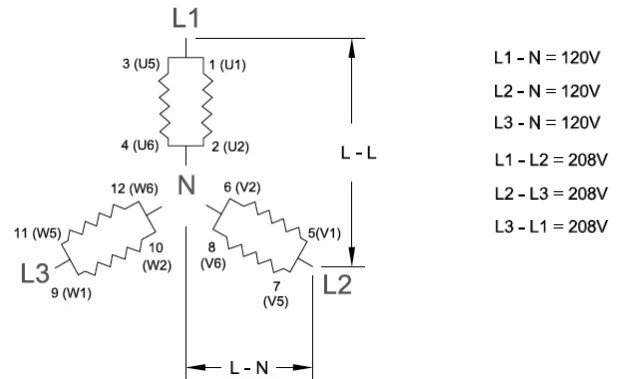
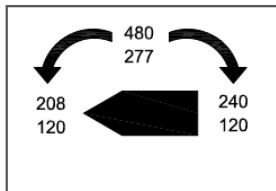

AC Generator Startor Winding connected for
3Phase Low Wye: 480/277 VAC 60Hz

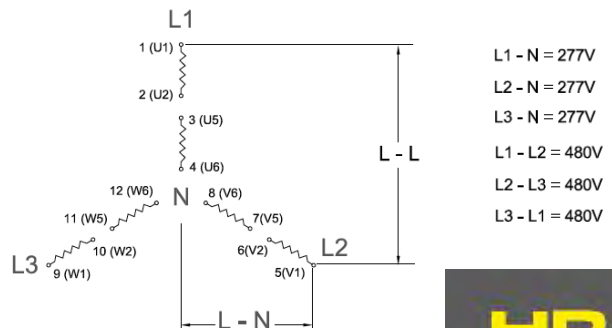
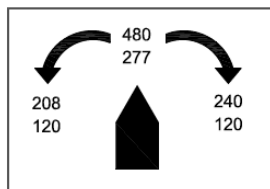

CEM7 Auto-start control panel

1. Voltage between each Phase & Neutral.
2. Voltage between Phases.
3. Current (Amps) on each Phase.
4. Frequency.
5. Active, Apparent & Reactive Power.
6. Power Factor.
7. Instant Power (kWH) and Accumulative power (day, month & year).
8. Fuel reserve.
9. Oil pressure, coolant temperature.
10. Battery voltage.
11. Battery charging alternator voltage.
12. Engine Speed.
13. Hours running (total & partial).

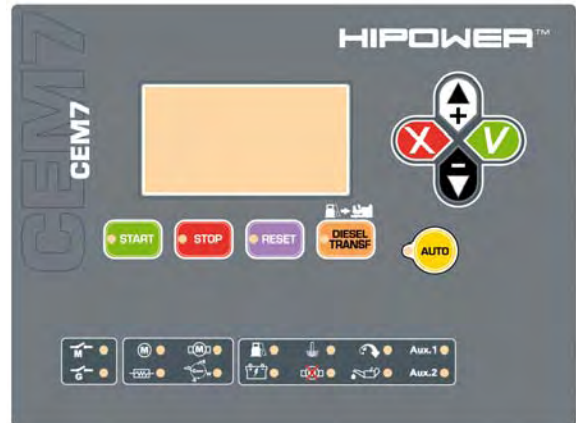

NOTES :

- ★ All the protections are programmable to carry out "Warning Alarm without engine stop" or "Alarm with Engine Stop (with or without cooling cycle)".
- ★ (A) Alarm with Engine Stop.
- ★ (W) Warning Alarm without Engine Stop.
- ★ (1) Sensor installation necessary.



Engine Alarms

1. High coolant temperature (A).
2. Low oil pressure (A).
3. Low coolant level (A).
4. Unexpected shutdown.
5. Low fuel level (W).
6. Stop failure.
7. Battery voltage failure (W).
8. Battery charging alternator failure (W).
9. Overspeed (A).
10. Under-speed (A).
11. Start failure.
12. Emergency stop.

Generators Alarms

1. Over-load (A).
2. Unbalanced voltage (A).
3. Over voltage (A).
4. Under voltage (A).
5. Over frequency (A).
6. Under frequency (A).
7. Short-circuit (A).
8. Reverse Power (A).
9. Incorrect phase sequence (A).

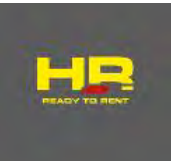

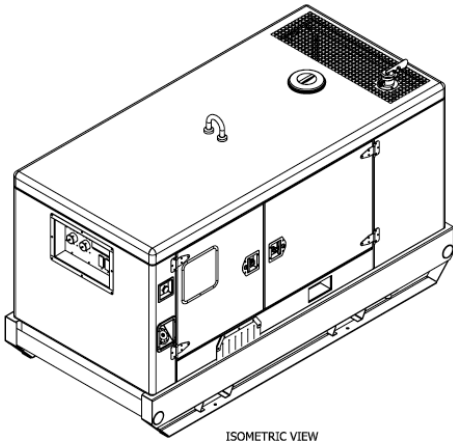

Industrial Rental Towable Generator

Model: HRJW 35 T6

ISOMETRIC VIEW

Enclosure model	CR			
	(Length x Width x Height)			
Overall size (L x W x H)	in	88.6 x 43.3 x 53.4		
	mm	2250 x 1100 x 1357		
Dry weight (with std. accessories)	Lb	Kg	2260	1025
Trailer size (L x W x H)	in	158.2 x 77 x 14		
	mm	4018 x 1955 x 355		
Trailer weight	Lb	Kg	850	386
Fuel Tank Capacity	Gal	L	26.4	100
Run Time (Hr)	100%	75%	50%	25%
	10.5	14	21.3	42.5

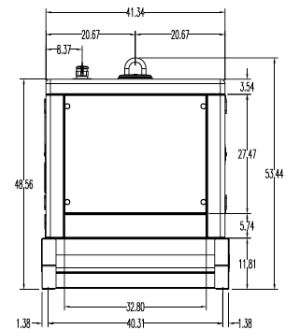
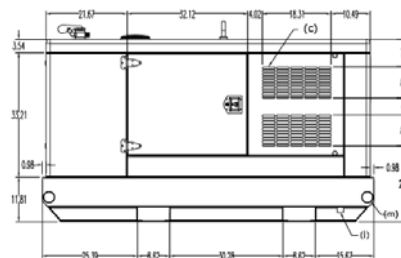
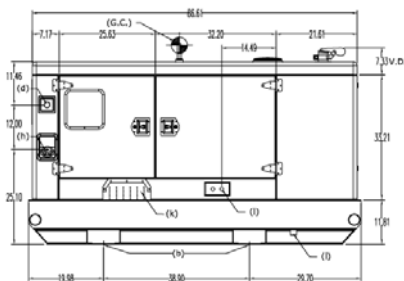
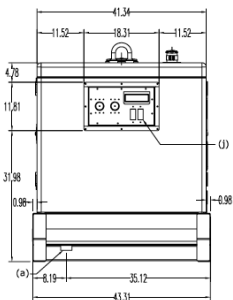

NOTE: The drawings are only representative of the overall dimensions.

 For full detailed drawings please consult your local distributor or contact Himoina Power Systems www.hipowersystems.com

HIPOWER reserves the right to modify any characteristic without prior notice. The illustrations may include optional equipment and/or accessories. Not contractual images. The technical indications described correspond to the information available at the moment of printing or editing.

Distributor:

