

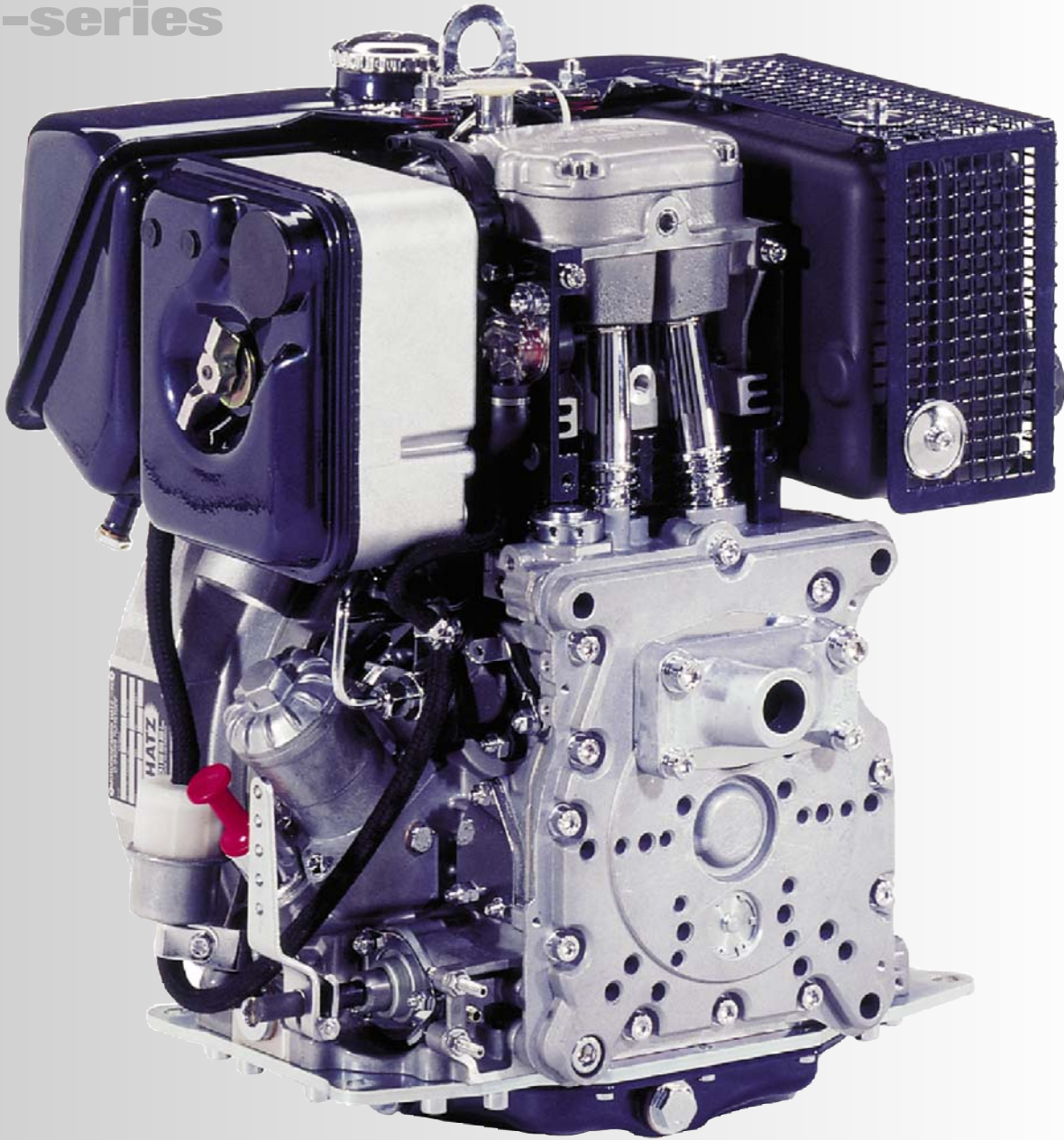

D-series

Update of established 1D41



1D42 • 3.0 - 7.5 kW

HIGHER POWER OUTPUT -
SINGLE-CYLINDER DIESEL ENGINES
WITH PROGRESSIVE TECHNOLOGY

SUPRA

1D42 - EPA IV

Features

- increase of swept volume by 7 %
- improved acceleration torque
- unchanged outside dimensions
- power increase up to 16%, increase of speed up to 22 %
- compliance with the strict EPA-IV exhaust limit values which have to be fulfilled as of 2010

Technical data		1D41.	1D42.
Number of cylinders		1	1
Bore x stroke	mm	90 x 65	90 x 70
	inches	3.54 x 2.56	3.54 x 2.76
Displacement	l	0.413	0.445
	cu.in.	25.2	27.2
Mean piston speed at 3000 r.p.m.	m/s	6.5	7.0
	ft/min	1280	1378
Compression ratio		21.0	22.5
Lub. oil consumption, related to full load		approx. 0.5% of fuel consumption	
Speed control	Idle speed	approx. 800 r.p.m.	
	static speed droop	approx. 5% a 3000 r.p.m.	

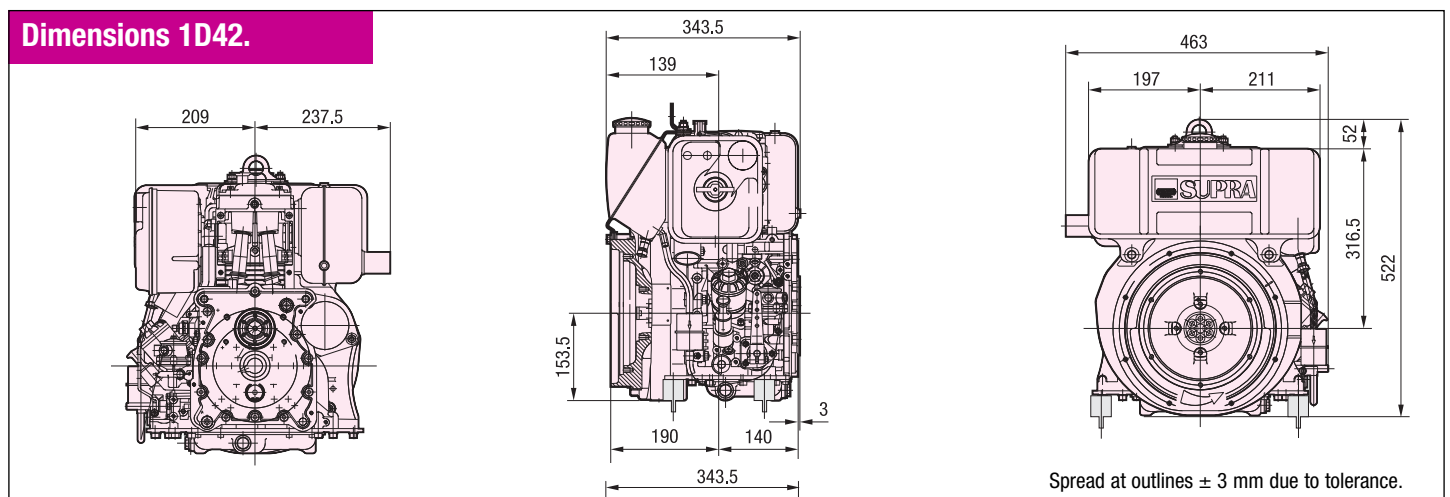
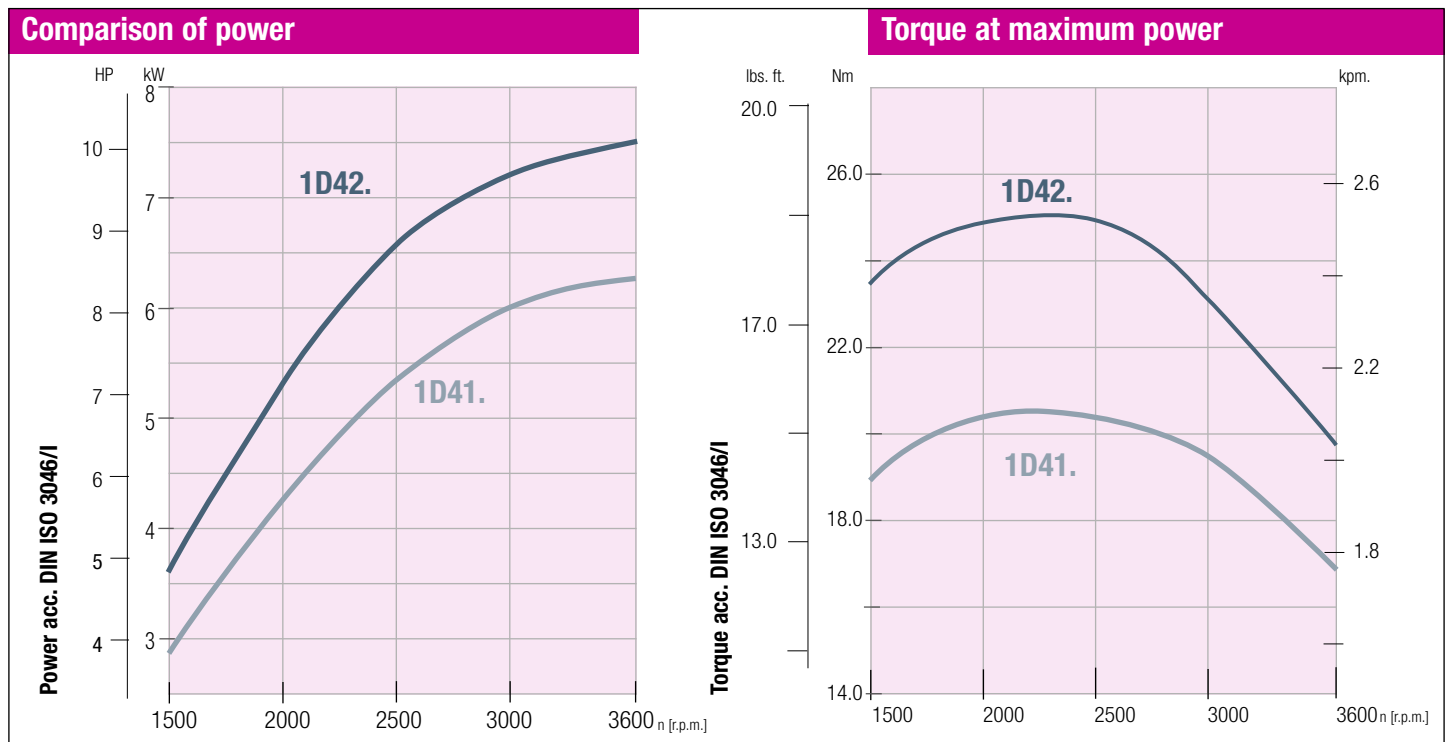

**MOTORENFABRIK HATZ
GMBH & CO. KG**
Ernst-Hatz-Straße 16
D-94099 Ruhstorf
GERMANY

Telephone: +49 (0) 85 31 / 319-0
Telefax: +49 (0) 85 31 / 31 94 18
marketing@hatz-diesel.de

www.hatz-diesel.com