

TD 2011

The Construction Equipment Engine. 23–56 kW | 31–75 hp at 1600–2800 rpm

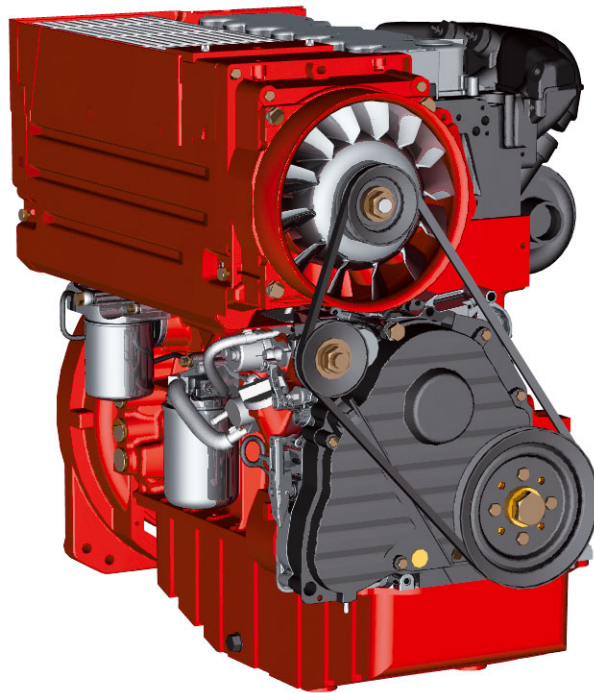

The engine company.



Your benefits

- Compact dimensions. Takes up less space and reduces installation costs.
- The 2011 model series offers an outstanding power-to-weight ratio.
- Low exhaust emissions for a clean environment. Compliance with 2004/26/EU level III A and EPA TIER III for mobile equipment.
- High reliability combined with long maintenance intervals and low wear.
- Low noise emission eliminates the need for costly noise-reducing soundproofing measures.

Characteristics

Compact dimensions | Naturally-aspirated 2-, 3- and 4-cylinder in-line engines | Turbocharging also for 4-cylinder engines | With integrated cooling system | Power take-offs for driving hydraulic pumps up to 28 kW/2800 rpm | All service points located on one side of the engine

TIER III/level III A performance for mobile working machines ¹⁾

Engine model		D 2011 L2 i	D 2011 L3 i	D 2011 L4 i	TD 2011 L4 i
Number of cylinders		2	3	4	4
Bore/stroke	mm inch	94/112 3.7/4.4	94/112 3.7/4.4	96/125 3.8/5.0	96/125 3.8/5.0
Swept volume	l cu inch	1.55 95	2.33 142	3.62 221	3.62 221
Compression ratio		1 : 19	1 : 19	1 : 19	1 : 18
Max. rated speed	rpm	2800	2800	2600	2600
Mean piston speed	m/s ft/sec	10.5 34.4	10.5 34.4	10.5 34.4	10.5 34.4

Performance for mobile working machines ¹⁾

Output according to ISO 14396	kW hp	23 31	35.8 48	46 62	56 75
At engine speed	rpm	2800	2800	2600	2600
At mean, effective pressure	bar lb/inch	6.3 91	6.6 96	6.1 88	7.4 107
Max. torque	Nm lb/ft	90 66	137 101	190 140	250 184
At engine speed	rpm	1700	1700	1700	1600
Minimum idle speed	rpm	900	900	900	900
Specific fuel consumption ²⁾	g/kWh lb/hp-hr	225 0.37	225 0.37	230 0.38	230 0.38
Weight according to DIN 70020, Part 7A ³⁾	kg lb	175 386	217 478	270 595	267 589

Dimensions

in mm inch	A	B	C
D 2011 L2 i	487 19.2	451 17.8	683 26.9
D 2011 L3 i	599 23.6	451 17.8	678 26.9
D 2011 L4 i	710 28.0	467 18.4	713 28.1
TD 2011 L4 i	710 28.0	530 20.9	713 28.1

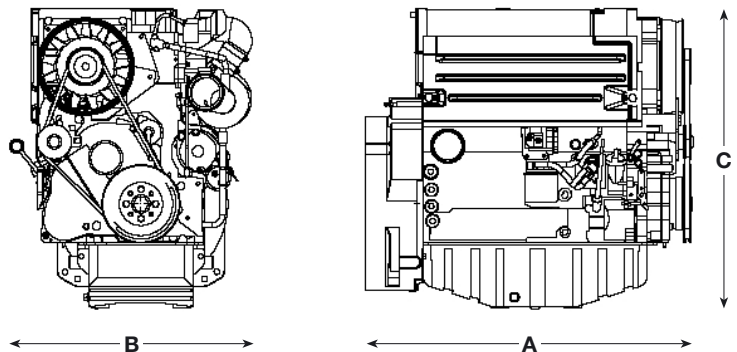

1) Gross flywheel output data including integrated cooling system.

2) At best point. Specific fuel consumption with reference to diesel fuel with a density of 0.835 kg/dm³ at 15 °C (6.96 lb/US gallon at 60 °F).

3) Including integrated cooling system, flywheel and SAE housing, but without starter motor, alternator and fluids.

The values specified in this datasheet are for information purposes only and are not binding.

The information given in the quotation is decisive.