

FMC BEAN Triplex Piston Mud Pump Unit

Group Model

KA019R51-12

Description : Diesel powered FMC Bean Triplex Piston Mud Pump unit designed for continuous duty drilling application.

Diesel Engine Model :

Type:
No. of cylinders (Motor):
Fuel :
Combustion Type :
Aspiration :
Fuel consumption at Full capacity :
Fuel Tank Capacity :
Cooling System :

Lombardini 9LD 625/2
4-Stroke
2 cyl. (0.435 L)
Diesel
Direct Injection
Natural Aspiration
253 g/kWh @ 3000 Rpm
10 L (*optional)
Air-Cooled by Flywheel Fan

Net Continuous Hp :
Net Intermittent Hp :
Starting System

23.2 hp (17.1 kW) @ 3000 Rpm
25.5 hp (18.8 kW) @ 3000 Rpm
12 V Electric

Water Pump Model :

No. of Pistons (Pump) :
Stroke :
Internal Gear Reduction Ratio :
Crankcase Material :
Max. Rated Rpm / GPM :
Max. Rated Hp :
Max Output Pressure :
Actual Max. Rpm / GPM :

FMC (BEAN) W1122BCD
3 piston
2 3/4"
3.6 : 1
Cast Iron
890 Rpm / 52 GPM
36.1 hp
1000 psi
600 RPM / 33 GPM

Reduction Gearbox Model :

Ratio :
Rated up to :
Transmission Case Material :

Technodrive RM45
5 : 1
16 hp
Aluminum

Safety Pressure Relief Valve :

Working Pressure / Size:
Casting :
Internal Seat :
Rated Flow at 1115 psi (10% overpressure) :

Farris 2700 series
1000 psi / 1" NPT
Cast Iron
Stainless Steel
65 gal/min.

Notes :

- Engine rating are as follow ISO 3046/1
- Specifications are subject to change by Marindustrial and/or its suppliers to update and improve the product.

Weight and Dimensions:

Length : 1524 mm (60 po)
Width : 838 mm (33 po) ; Frame only (24 po)
Height : 838 mm (33 po)
Weight : 455 kg (1000 lbs) approx.

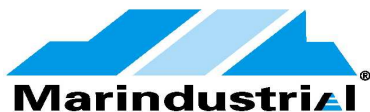

www.marind.ca

MONTREAL
MONCTON
OAKVILLE

Tel. 514-342-2748
Tel. 506-852-3332
Tel. 905-829-3004

info-quebec@marind.ca
info-atlantic@marind.ca
info-ontario@marind.ca

FMC Technologies

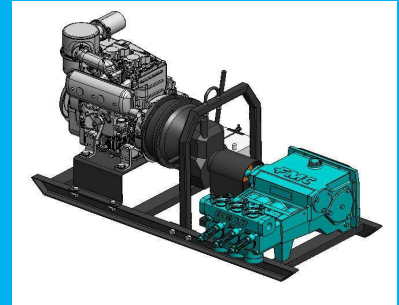

Standard Equipment

- Jaw Coupling with Safety Guard
- Adjustable Pressure Relief Valve
- Battery Rack
- Battery Cables
- 530 CCA Battery
- 12 V Electric Start
- Welded skid mount steel base frame with handles and coped ends for easy transport.
- Single point lifting bail

Options

- Spare parts kits
- Others by request

KA019R51-12