

NEWAGE

Driveline Solutions

415 SERIES AXLE

OVERALL AXLE RATIO

- 14.8:1, 18.04:1

HYDROSTATIC TRANSFER GEARBOX RATIO

- 1.53:1, 1.76:1, 2.13:1

MAXIMUM LOAD RATING

- 5200 kg (11440 lb) based on 1475 mm wheel track and axle mountings at 960mm centres.

TORQUE

- Nominal output torque at both wheels is 13222 Nm (9750 lbf.ft).

BRAKES (OPTIONAL)

- Maximum braking torque at both wheels: 9112 Nm (6720 lbf.ft), based on axle ratio of 14.8:1 and two friction plates per side.
Hydraulic operating pressure: 60 bar (900 psi).

PARKBRAKE (OPTIONAL)

- Maximum braking torque at both wheels: 9990 Nm (7368 lbf.ft).
Cable pull at axle: 2670 N (600 lbf), operating at 180 mm centres.

APPROXIMATE WEIGHT

- Model: 415PB (standard input): 166 kg (365 lb)
- Model: 415PBH (hydrostatic): 240 kg (528 lb)

APPROXIMATE OIL CAPACITY

- 6 litres (10.6 pints)

OPTIONS

- Integral transfer gearbox with hydrostatic motor input ratios up to 2.13:1. Adapters for all major hydrostatic motor suppliers can be supplied.

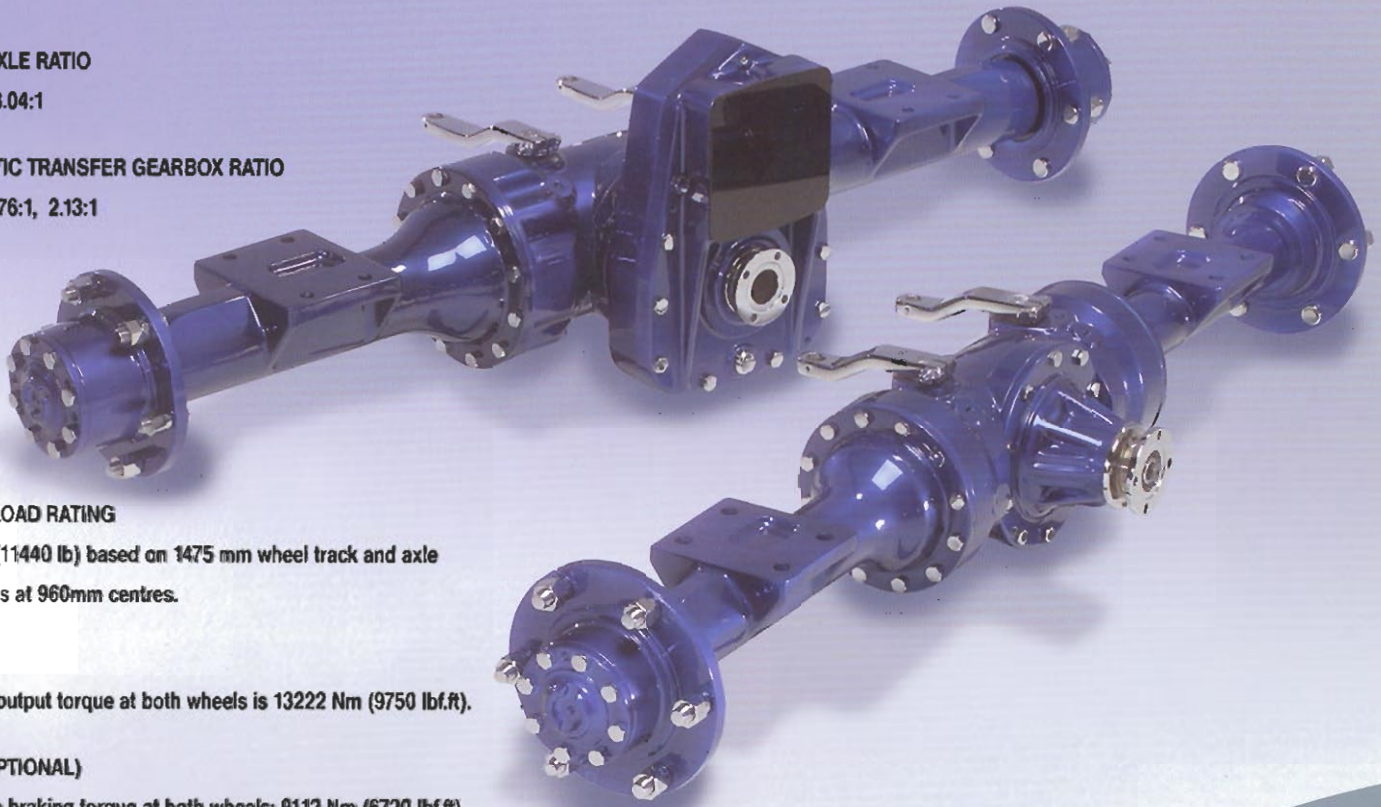

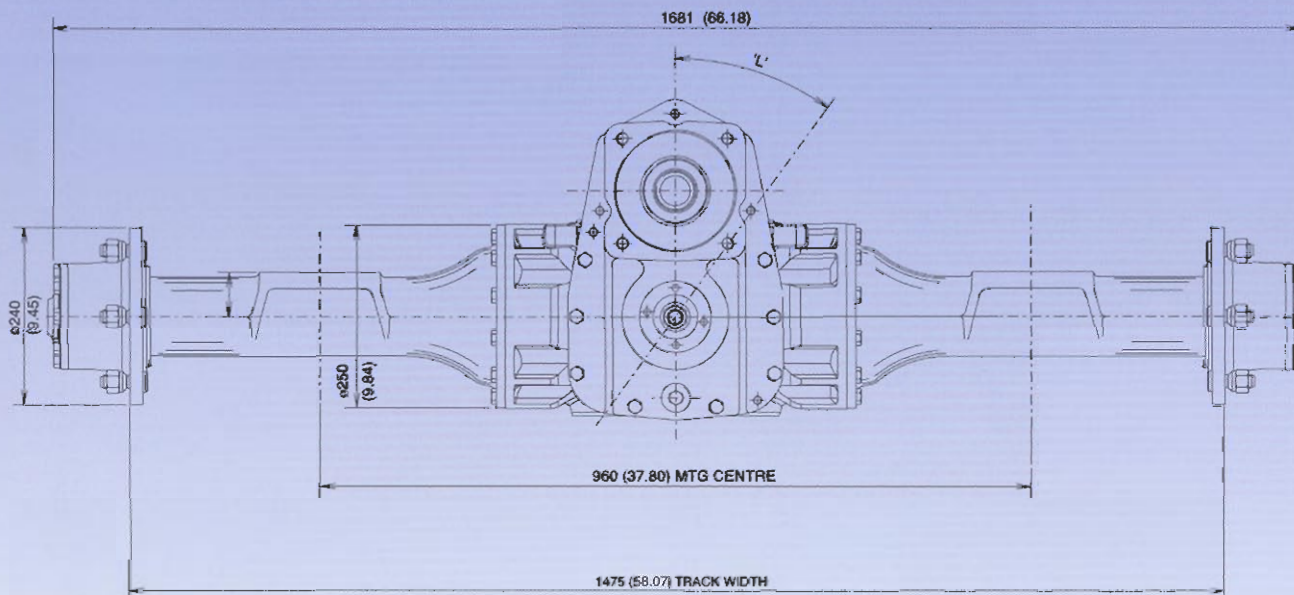
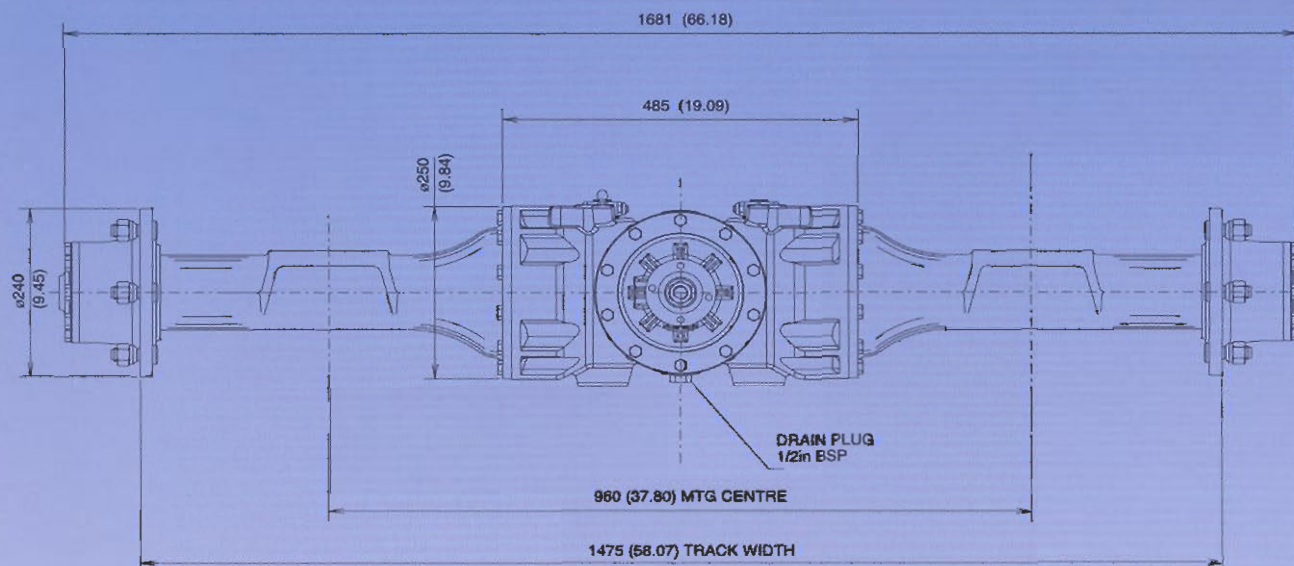

WHEEL FIXING OPTIONS

- 6 studs: M18 thread x 2 mm pitch on 205 mm PCD, with 158/159 mm wheel spigot diameter.
- 6 studs: 7/8" BSF on 205 mm PCD, with 158/159 mm wheel spigot diameter.
- 8 studs: M18 thread x 2 mm pitch on 275 mm PCD, with 220 mm wheel spigot diameter.
- 8 studs: 7/8" BSF on 275 mm PCD, with 220 mm wheel spigot diameter.

MOUNTING OPTIONS (STANDARD)

- 4 off 18 mm diameter holes: 150 mm by 83 mm hole centres, on rigid mounting pads, with 960 mm mounting centres.



Certificate No. Q10728.

Note:
In line with our policy of continuous product development and improvement, specifications of Newage driveline equipment may be subject to change without notice.



EXCLUSIVE AUTHORIZED DISTRIBUTOR

MARINDUSTRIEL
8550, DELMEADE
MONTRÉAL, (QC) H4T 1L7
TEL. : 514.342.2748
800.363.2259
FAX : 514.342.6151
info-quebec@marind.ca

MARINDUSTRIAL INC.
80, HARRISVILLE BLVD. UNIT « A »
MONCTON, (NB) E1H 3N4
PHONE : 506.852.3332
800.463.3332
FAX : 506.857.8484
info-atlantic@marind.ca

MARINDUSTRIAL ONTARIO INC.
2320, BRISTOL CIRCLE, UNIT # 8
OAKVILLE, (ON) L6H 5S3
PHONE : 905.829.3004
800.866.3831
FAX : 905.829.4046
info-ontario@marind.ca