

# NEWAGE

Driveline Solutions

## 100 SERIES AXLE

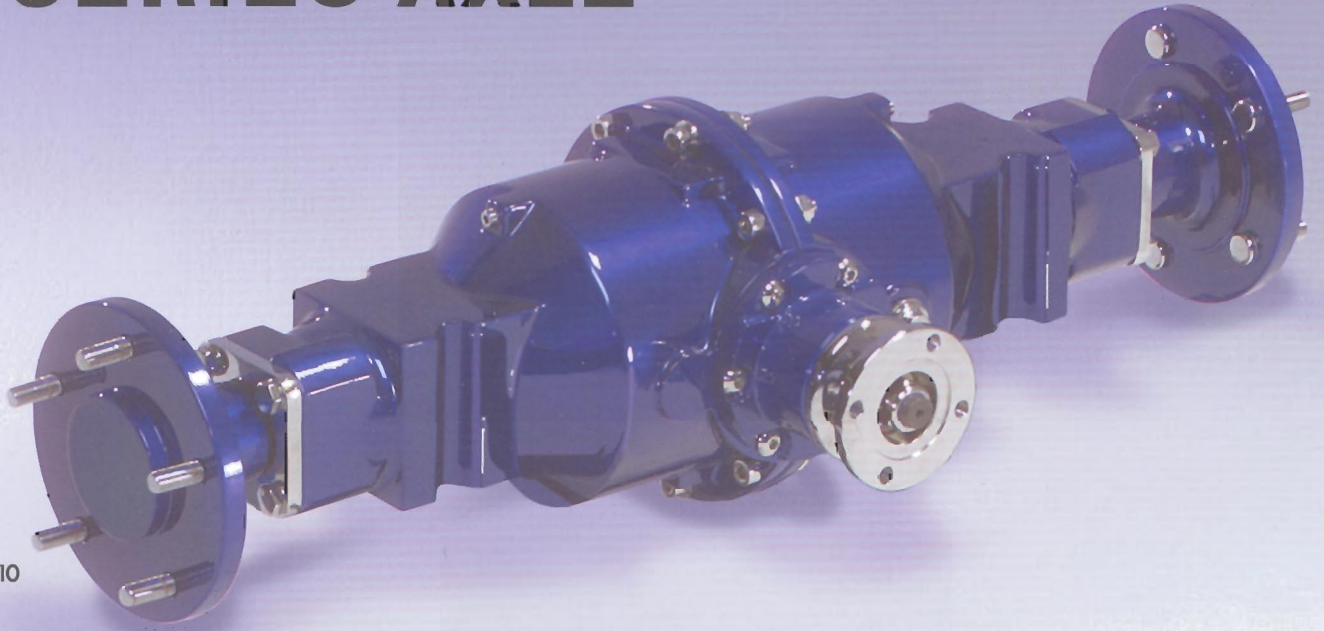

### OVERALL AXLE RATIO

- 14.8:1

### MAXIMUM LOAD RATING

- 1000 kg (2205lb) based on 786 mm wheel track and axle mountings at 410 mm centres.

### TORQUE

- Maximum output torque at both wheels is 1800 Nm (1327 lbf.ft).

### BRAKES (OPTIONAL)

- 220 mm diameter x 40 mm drum brakes mounted on output flanges. Operated by 22 mm diameter wheel cylinder. Maximum braking torque at both wheels: 14600 Nm (10767 lbf.ft). Hydraulic operating pressure: 30 bar (3200 psi).

### PARKBRAKE (OPTIONAL)

- Maximum braking torque at both wheels: 1000 Nm (737 lbf.ft). Cable pull at axle: 620 N (140 lbf).

### APPROXIMATE WEIGHT

- 76 kg (167 lb)

### APPROXIMATE OIL CAPACITY

- 2.0 litres (3.5 pints)

### WHEEL FIXING OPTIONS

- 5 studs: M12 x 1.5 mm pitch on 140 mm PCD.

### MOUNTING OPTIONS

- Rigid mounting by U bolts at 140 mm fixing centres.



# BASIC INSTALLATION DATA - 100

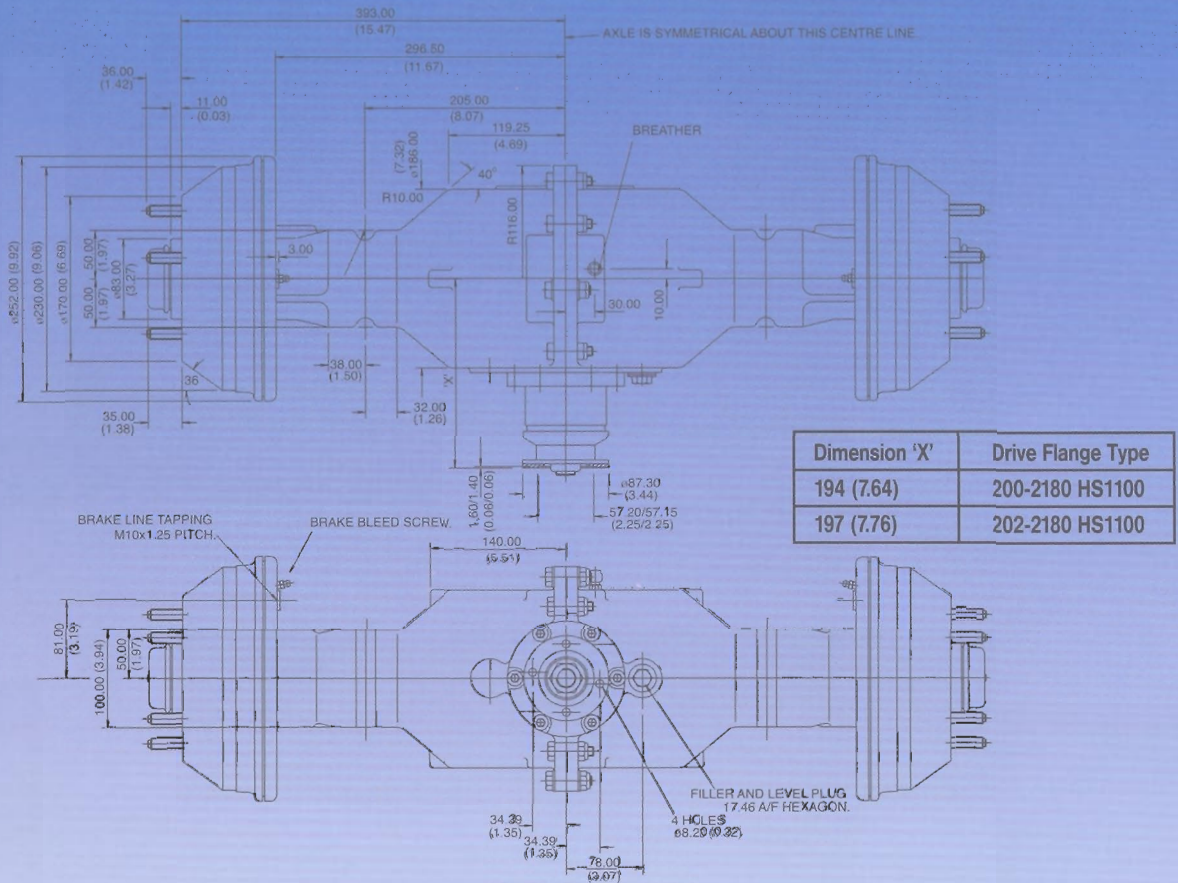

Dimension 'X'	Drive Flange Type
194 (7.64)	200-2180 HS1100
197 (7.76)	202-2180 HS1100

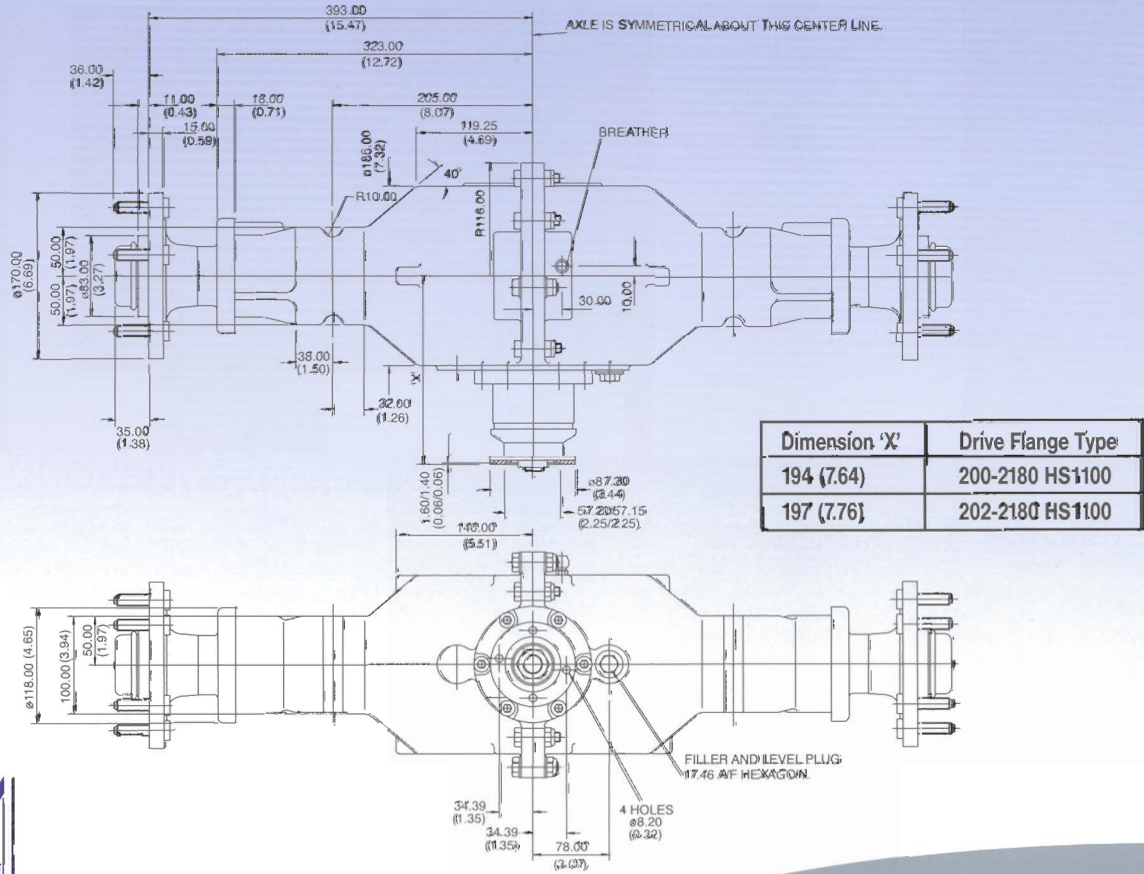

Dimension 'X'	Drive Flange Type
194 (7.64)	200-2180 HS1100
197 (7.76)	202-2180 HS1100



Certificate No. 010729.

**Note:**

In line with our policy of continuous product development and improvement, specifications of Newage driveline equipment may be subject to change without notice.



EXCLUSIVE AUTHORIZED DISTRIBUTOR

MARINDUSTRIEL  
8550, DELMEADE  
MONTREAL (QC) H4T 1L7  
TEL : 514.342.2748  
800.363.2259  
FAX : 514.342.6151  
info-quebec@marind.ca

MARINDUSTRIAL INC.  
80, HARRISVILLE BLVD. UNIT « A »  
MONCTON, (NB) E1H 3N4  
PHONE : 506.852.3332  
800.463.3332  
FAX : 506.857.8484  
info-atlantic@marind.ca

MARINDUSTRIAL ONTARIO INC.  
2320, BRISTOL CIRCLE, UNIT # 8  
OAKVILLE, (ON) L6H 5S3  
PHONE : 905.829.3004  
800.866.3831  
FAX : 905.829.4046  
info-ontario@marind.ca