



Pictures may include optional equipment and/or accessories.



**Model: HJW 30 M6**

**Ratings Range - 60Hz Operation**

Standby	kW	26
	kVA	32
Prime	kW	24
	kVA	30

**Sound Attenuation:**  
at 7m / 23 ft    62 dBA

**Key features**

HIPOWER industrial generators are an efficient, reliable and versatile source of power for Stationary Standby or Prime Power Applications.

The Genset features a heavy-duty John Deere 4 cycle diesel engine certified by the Environmental Protection Agency (EPA) to conform to Tier 4 non-road emissions regulations, an AC high capability alternator regulated by a precise Automatic Voltage Regulator controlled and protected by our own auto-start CEM7 control panel available CANBUS communications including a powerful microprocessor and easy user programming. A heavy-duty constructed chassis supports the complete set. The generator is protected by a best-in-class sound attenuated enclosure designed for prime or standby applications.

- Engine - generating set tested to ISO 8528-5.
- The Genset engine is certified by the Environmental Protection Agency (EPA) Tier 4 non-road emissions regulations.
- The brushless, single bearing, 4 poles, 12-wire generator end, with automatic voltage regulator has broad range reconnectability.
- The Genset is CSA certified and is available as UL2200 listed.
- Generating set meets NFPA 110, level 1, when equipped with the necessary accessories and installed per NFPA standards.
- Global product support.
- Operations and maintenance manuals.
- 2 Year Standby Warranty Standard. Extended warranties are also available.

**Genset Ratings**

GENSET Model	ENGINE Model	ALTERNATOR Model	VOLTAGE L-N   L-L	Ph	Hz	150°C RISE STANDBY RATING			125°C RISE PRIME RATING		
						kW	kVA	Amps	kW	kVA	Amps
HJW 30 M6	4024TF281 - 36	PI 144 K	120/240	1	60	26	32	133	24	30	124

HIPOWER reserves the right to modify any characteristic without prior notice. The technical indications described correspond to the information available at the moment of printing or editing.

**NOTES :**

★ "Ratings definitions & Reference Conditions".

★ Performance data refers to ISO 8528/1 Standard Reference Conditions: +25 °C (77°F) air temperature, 100m (3285ft) altitude, 30% relative humidity.

★ Standby power ratings do not have an overload capability but can be used for the duration of the utility failure in accordance with ISO-3046/1, BS5514, AS2789, and DIN6271. No overload is available.

★ Prime power (Unlimited Running Time) ratings are continuous in accordance with ISO-8528. 10% overload is available for a maximum of 1 hour in 12 hours of operation, in accordance with ISO-3046/1, BS 5514, AS2789, and DIN 6271.

★ The ratings may be subject to derate at different operating conditions. Please request Derate Guidelines for other conditions.

★ All single-phase units are rated at 1 power factor.



## Standard features

### Engine

- Industrial grade Tier 4 John Deere diesel Engine.
- 4 stroke, water cooled, provided with:
- Electric start 12V.
- Radiator with pusher fan.
- Standard water separator not visible level fuel filter . J1939 stop the engine with ECU John Deere.
- Electronic governor.
- HWT/LOP senders.
- Heavy duty 2-stage air filter
- Hot & rotating components (exhaust, fan,...) protections and radiator guards.
- Oil drain hand pump
- Spin type fuel and oil filters.

### Alternator

- Self excited, self regulated alternator.
- Insulation class H, IP23 Protection.
- Automatic Voltage Regulator.
- Vacuum impregnation.

### Control Panel

- Digital microprocessor based control panel with remote start capability.
- CEM7 Auto-start control panel ("DEEP SEA" for UL option)
- **Engine protections:** High coolant temperature **(A)**, High coolant temperature by sensor **(W)**, Low engine temperature by sensor **(W)**, Low oil pressure**(A)**, Low coolant level**(A)**, Unexpected shutdown, Fuel level **(W)**, Stop failure, Battery voltage failure **(W)**, Battery charging alternator failure **(W)**, Overspeed**(A)**, Underspeed**(A)**, Start failure, Emergency stop.

- **Alternator protections:** Over frequency **(A)**, Under frequency **(A)**, Over voltage **(A)**, Under Voltage **(A)**, Over amperage **(A)**, Short-circuit**(A)**, Unbalanced voltage **(A)**, Incorrect phase sequence **(A)**, Reverse power **(A)**, Overload **(A)**.
- **Genset readings:** Voltage among phases, Voltage among phases and neutral, Amperage, Frequency, Apparent power(kVA), Active power (kW), Reactive power (kVAr), Power factor.
- **Engine readings:** Fuel level(%), Battery voltage, R.P.M, Battery charge alternator voltage, Coolant temperature (optional) **(1)**, Oil pressure (optional) **(1)**.
- **Digital Metering:** Total hour counter, Partial hour counter, kW meter, Starts valid and Starts failure counters, Maintenance.
- **Communications (optional):** RS232, RS485, J1939, Modbus, CCLAN, Software for PC, Analog modem, GSM/GPRS modem, Remote screen, Tele-signal.
- **Other features:** Alarms history, External start, Start inhibition, Start under EJP normative, Pre-heating engine control, Genset contactor activation, Fuel transfer control, Engine temperature control, Manual Override, Programmable alarms, Genset start function in test mode, Programmable outputs, Magnetic Pick-up control.
- **Multilingual capability**
- Remote Communications to our **RAM7** Remote Annunciator Module.
- **NFPA110** Level Compatible.
- On/Off Switch.
- Emergency Stop Button.

**NOTES :**

★ All the protections are programmable to carry out "Warning Alarm without engine stop" or "Alarm with Engine Stop (with or without cooling cycle)".

★ **(A)** Alarm with Engine Stop.

★ **(W)** Warning Alarm without Engine Stop.

★ **(1)** Sensor installation necessary



## Standard features

### Power Panel.

- Main Line Circuit Breaker for overload protection (CSA, UL and UL-C listed).
- Main bus / Hardwire connection panel with safety protection. (open thermal magnetic protection and alarm)
- Fuel cut-off solenoid and safety switches.

### Electric Equipment.

- Battery charging alternator.
- Gel type, heavy-duty Starting battery(s) installed and connected to the engine include cables and rack.
- Ground connection prepared for ground spike (not supplied).

### Chassis

- Skid with integral day fuel tank. (non UL)
- Fully welded steel skid with forklift pockets and 110% spill containment.
- Chassis ready for mobile kit installation or Extended capacity fuel tank. (see models and mobile kit options).
- Easy access for chassis cleaning and fast draining of fuel tank.
- Vibration isolators between chassis and generator.

### Enclosure

- Sound attenuated canopy made with high quality 11 gauge steel.
- Powder coat paint which exceeds 1,000 hour salt spray test.
- Heavy-duty construction designed for prime or standby applications.
- Stainless steel hardware and fasteners.
- Ultra silent all weather enclosures with Rock-Wool insulation and curved edges with minimum outside fasteners.
- Single eye lifting point.
- Emergency stops (double protection for emergency stop; inside on control panel + external on canopy)
- Door with window to view control panel.
- Easy access to radiator fill through roof on enclosure.

### Exhaust

- Steel residential silencer of -35dBA attenuation, with rain cap. (optional for Open Skid genset versions).



Model: HJW 30 M6

## Optional features

### Engine (optional)

- Water Jacket Heater
- Low coolant level sensor.
- Secondary water separator fuel filter - RACOR type (Decanting filter with water detection kit, alarm signal and sensor contact).
- Heavy duty, three stage air filter with service indicator.

### Alternator (optional)

- Permanent Magnet Generator (PMG).
- Anti-condensation heater

### Electric Equipment (optional)

- Battery isolator.
- Automatic battery chargers.

### Electronics (optional)

- Remote Annunciator Module RAM7 to meet NFPA 110 installation.
- Digital timer.
- CANBUS - LAN, converter.
- CANBUS - USB, converter.
- CANBUS – J1939, converter (series >HJW 85 T6 / HJW 410 T6).
- Communication modules for tele-control.
- Transfer switch and MPS paralleling control panel.
- Multiple remote annunciation options (CAN/USB, GSM, RS232, RS485..).

### Chassis (optional)

- Sub-base UL 142 double wall fuel tanks to customer specification.
- Oil field type skid.

### Trailers (optional)

- Road towing trailers to DOT standards.



Model: HJW 30 M6

## Engine specifications

GENERAL DATA		
Manufacturer		<b>JOHN DEERE</b>
Engine model		<b>4024TF281 -36</b>
EPA Certification for:	Stage	<b>Tier 4</b>
Rated	RPM	1,800
Nominal Power (PRIME)	kW - HP	32      43
Nominal Power (STANDBY)	kW - HP	36      49
Engine type		Diesel 4 stroke
Inyection type		DIRECT
Aspiration type		TURBO CHARGED
Cylinder arrangement		4 - L
Bore and stroke	(mm) - In	(86 x 105)    3.4 x 4.1
Displacement	L - in3	2.4      149
Cooling system		Liquid (Cool-Gard II)
Governor Type		electronic
Make		c
Standard		c
Starting voltage	Vcc	12
Air cleaner type		Medium duty w/double cartridge
Compression ratio		20.5 : 1



Model: HJW 30 M6

## Alternator specifications

GENERAL DATA	
Manufacturer	<b>Stamford</b>
Model	<b>PI 144 K</b>
Alternator Type	4 poles, rotating field
Excitation system	
Exciter Type	Brushless, self-excited
	EBS (Optional)
Leads: quantity, type	12, reconnectable
Stator Pitch	2/3
Insulation system	
Material	Class H
Temperature rise	150°C Standby 125°C Prime
Bearing: quantity, type	Single bearing sealed
Coupling	Flexible disc
Amortisseur windings	Full
Automatic Voltage regulator	
STD regulator	AS480
PMG regulator or EBS	Opt. EBS (Excitation Boots System)
Voltage regulation, no load to full load	
STD regulator	+/-1%
PMG regulator	+/-1%
Load acceptance	100% of rated standby current
Unbalanced load capability	
Subtransient Reactance	
240V	17%
TIF	<50
Line Harmonics	5% Maximum
Peak motor starting kVA:	30% dip
240V	
240V	



**Application data**

EXHAUST SYSTEM		PRIME	STANDBY
Exhaust manifold type		Dry	Dry
Exhaust outlet diameter			
Open Skid version	mm - In	45 - 1.77	
Sound Attenuated version	mm - In	65 - 2.56	
Max. Exhaust temp. at full load	°C	517	552
	°F	963	1026
Exhaust Gas Flow	kg/h - Lb/h	186.48 - 411.12	201.6 - 444.45
	(m3/min) - ft3/min	(7.4) - 261	(8.0) - 283
Evacuated by the exhaust heat	kcal/kWh - kcal/kWh	0.00 - 920.15	
Maximum allowed back pressure	(mm/H2O) - inH2O	762 - 30	
	(kPa) - inH2O	7.5 - 30	
COOLING SYSTEM			
Engine cooling air flow	m3/s - ft3/s	2.6 - 92.0	
Generator cooling air flow	m3/min - ft3/min	1.2 - 41.3	
Total cooling air flow (engine + generator + combustion)			
Open Skid version	m3/min - ft3/min	322.0 - 11,371.3	
Sound Attenuated version	m3/min - ft3/min	418.0 - 14,761.5	
Total cooling capacity	l - gal	12.2 - 3.2	
Antifreeze recommended	l - gal	6.1 - 1.6	
LUBRICATION SYSTEM			
Oil Filter: quantity, type		1 x Cartridge	
Oil pan capacity	l - gal	7 - 1.85	
Oil pan capacity with filter	l - gal	5 - 1.32	
Oil cooler		Water Cooled	
Recommended Oil		15W-40 or API CI-4 PLUS o CI-4	
Specific oil consumption full load	% fuel	<0.1%	
Oil Press	(psi) - kPA	43 - 296	
VENTILATION REQUIREMENTS			
Air requirement for combustion at 100% load/rated speed	m3/h - ft3/h	180 - 6360	
Cooling airflow	m3/h - ft3/h	- - -	
Heat rejected to ambient:			
From engine	kW - btu/min	25 - 1412	
From alternator	kW - btu/min	0.92 - 52	



Model: HJW 30 M6

## Application data

ELECTRICAL SYSTEM		12V
Battery charging alternator:		
Ground (negative/positive)		Negative
Volts (DC)	V	12
Ampere rating	Amp	70
Starter motor rated voltage (DC)	V	12
Starter motor rated	kW	2.02
Starter motor rated	HP	2.75
Battery recommendations		
Quantity & Min. Amps rating	Amp	1 x 92
Min. Cold Cranking Amps	Amp	750
Battery Voltage (DC)	V	12

FUEL SYSTEM		
Recommended fuel		#2 Diesel
Fuel supply line. min. ID	mm - in	11 0.44
Fuel return line. min. ID	mm - in	6 0.24
Fuel pump Type		Engine Driven
Max. Lift fuel pump	m - ft	3 9.84
Max. Flow to pump	(l/h) - gal/h	99 26.1
Fuel filter		
Secondary filter		5µm @ 98% Eff.
Secondary Water Separator		Included
Primary filter		C
Primary Water Separator		C

FUEL CONSUMPTION		PRIME rating		STANDBY rating	
		l/h	gal/h	l/h	gal/h
100% Load	l/h - gal/h	9.5	2.5	10.6	2.8
75% Load	l/h - gal/h	7.2	1.9	7.8	2.1
50% Load	l/h - gal/h	4.7	1.2	5.3	1.4
25% Load	l/h - gal/h	2.4	0.6	3.2	0.8



Model: HJW 30 M6

## Control & Power Panel

1. CM Control Panel.
2. CEM7 Auto-start control panel.
3. On/Off Switch..
4. Emergency Stop.
5. CP Power Panel.
6. Main Line Circuit Breaker for overload protection.
7. Main bus /hardwire connection panel with safety protection.
8. Fuel cut-off solenoid and safety switches



Pictures may include optional equipment and/or accessories.

## CEM7 Auto-start control panel

1. Voltage between each Phase & Neutral.
2. Voltage between Phases.
3. Current (Amps) on each Phase.
4. Frequency.
5. Active, Apparent & Reactive Power.
6. Power Factor.
7. Instant Power (kWH) and Accumulative power (day, month & year).
8. Fuel reserve.
9. Oil pressure, coolant temperature.
10. Battery voltage.
11. Battery charging alternator voltage.
12. Engine Speed.
13. Hours running.

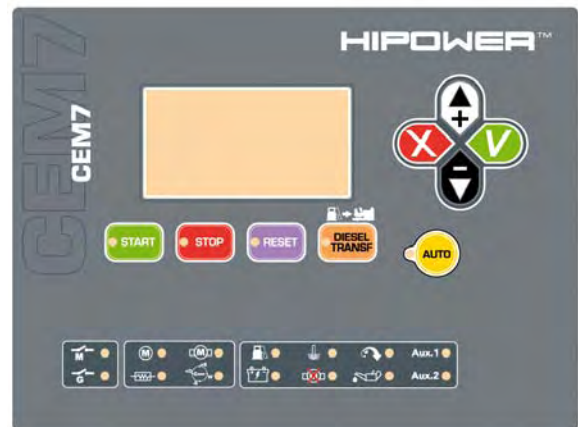

**NOTES :**

- ★ All the protections are programmable to carry out "Warning Alarm without engine stop" or "Alarm with Engine Stop (with or without cooling cycle)".
- ★ (A) Alarm with Engine Stop.
- ★ (W) Warning Alarm without Engine Stop.
- ★ (1) Sensor installation necessary.

## Engine Alarms

1. High coolant temperature **(A)**.
2. Low oil pressure **(A)**.
3. Low coolant level **(A)**.
4. Unexpected shutdown.
5. Low fuel level **(W)**.
6. Stop failure.
7. Battery voltage failure **(W)**.
8. Battery charging alternator failure **(W)**.
9. Overspeed **(A)**.
10. Under-speed **(A)**.
11. Start failure.
12. Emergency stop.

## Generators Alarms

1. Over-load **(A)**.
2. Unbalanced voltage **(A)**.
3. Over voltage **(A)**.
4. Under voltage **(A)**.
5. Over frequency **(A)**.
6. Under frequency **(A)**.
7. Over amperage **(A)**.
8. Short-circuit **(A)**.
9. Reverse Power **(A)**.
10. Incorrect phase sequence **(A)**.

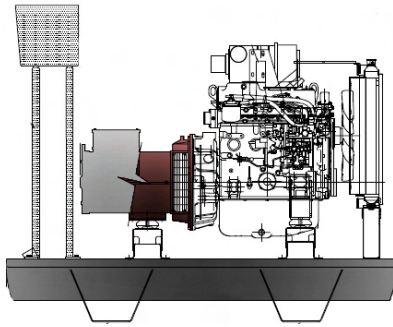
**Model: HJW 30 M6**
**OPEN SKID MODEL**

Overall size (L x W x H)	(Length x Width x Height)			
	mm	in	mm	in
	1850	72.8	780	30.7
			1280	50.4
Dry weight (with std. accessories)	kg	Lb	547	1205
	L	Gal	120	31.7
Fuel Tank Capacity	L	Gal	120	31.7
Run Time (Hr)	100%	75%	50%	25%
	Prime Power	12.6	16.9	25.6
	Standby Power	11.4	15.5	22.7
			37.5	

NOTE: The drawings are only representative of the overall dimensions.

For full detailed installation drawings please consult your local distributor or contact Himoina Power Systems [www.hipowersystems.com](http://www.hipowersystems.com)

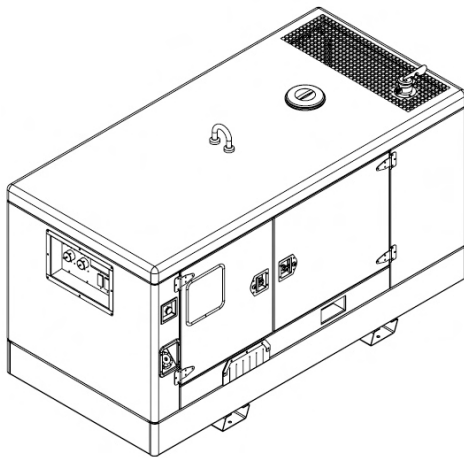
**SOUND ATTENUATED MODEL**

STANDARD SIZE	(Length x Width x Height)			
	mm	in	mm	in
	2200	86.6	1050	41.3
			1360	53.5
Dry weight (with std. accessories)	kg	Lb	1025	2260
	L	Gal	100	26.4
Fuel Tank Capacity	L	Gal	100	26.4
Run Time (Hr)	100%	75%	50%	25%
	Prime Power	10.5	14.1	21.3
	Standby Power	9.5	12.8	18.9
			31.2	

HIPOWER reserves the right to modify any characteristic without prior notice. The illustrations may include optional equipment and/or accessories. Not contractual images. The technical indications described correspond to the information available at the moment of printing or editing.

Distributor:

